



KERN & Sohn GmbH

Ziegelei 1

D-72336 Balingen

email: info@kern-sohn.com

Phone: +49-[0]7433- 9933-0

Fax: +49-[0]7433-9933-149

Internet: www.kern-sohn.com

Operating Manual

Electronic Moisture analyzer

KERN MLS_N

Version 2.0

02/2008

GB



MLS_N-BA-e-0820



KERN MLS_N

Version 2.0 02/2008

Operating Manual

Electronic Moisture analyzer

Table of Contents

1	TECHNICAL DATA	4
1.1	Dimensions	5
2	DECLARATION OF CONFORMITY	6
3	BASIC INFORMATION (GENERAL)	7
3.1	Proper use.....	7
3.2	Improper Use	7
3.3	Danger Information	7
3.4	Warranty	8
3.5	Monitoring of Test Resources.....	8
4	BASIC SAFETY PRECAUTIONS	8
4.1	Pay attention to the instructions in the Operation Manual	8
4.2	Personnel training.....	8
5	TRANSPORTATION & STORAGE	8
5.1	Testing upon acceptance	8
5.2	Packaging.....	8
6	UNPACKING, SETUP AND COMMISSIONING	9
6.1	Installation Site, Location of Use.....	9
6.2	Unpacking and erection.....	10
6.2.1	Scope of delivery.....	11
6.3	Mains connection	11
6.3.1	Switch on the unit.....	11
6.4	Connection of peripheral devices.....	11
6.5	Initial Commissioning	11
6.6	Keyboard overview.....	12
6.6.1	Operating the scales using PS keyboard.....	13
7	MENU	13
7.1	Navigation in the menu:.....	15

8	USER MENU	18
8.1	P1 Calibration (adjustment).....	19
8.2	P2 GLP (Good laboratory practice)	29
8.2.1	P3 Date/time	31
8.2.2	P4 display.....	33
8.2.3	P5 RS-232.....	35
8.2.4	P6 output.....	36
8.2.5	P7 General functions.....	42
9	OPERATOR MENU – MOISTURE ANALYSIS	43
9.1	Moisture analysis without using the program library	43
9.1.1	Disabling the program library	43
9.1.2	Setting drying parameters	44
9.1.3	How to implement drying	48
9.2	Moisture analysis using the program library.....	52
9.2.1	Enabling of program library	52
9.2.2	Setting drying parameters	53
9.2.3	How to save drying parameters	61
9.2.4	How to invoke drying parameters / drying	61
10	STORING MEASURED RESULTS	65
11	GENERAL INFORMATION CONCERNING MOISTURE ANALYSIS	66
11.1	Application	66
11.2	Basics	66
11.3	Adjustment to existing measuring method	66
11.4	Preparing a sample	66
11.5	Sample material	68
11.6	Sample size / originally weighted in quantity.....	68
11.7	Drying temperature	69
11.7.1	Drying temperatures above 160 °C (MLS 50-3HA250N only).....	69
11.8	Description of heating profiles	70
11.9	Recommendations / Guidelines.....	71
12	DATA OUTPUT	72
12.1	Remote control instructions	73
13	SERVICE, MAINTENANCE, DISPOSAL	74
13.1	CLEANING.....	74
13.2	Service, maintenance.....	75
13.3	Disposal.....	75
14	INSTANT HELP	76

1 Technical Data

Data	MLS 50-3IR160N	MLS 50-3HA160N	MLS 50-3HA250N
Radiator	Infrared (1 x 400 W)	Halogen (1 x 400 W)	Halogen (1 x 400 W)
Temperature range	40°C - 160°C	40°C - 160°C	40°C - 482.00°F
Maximum load (Max)	50 g		
Warm-up time	2 h		
Minimum for drying	0.02 g		
Readability (d) for originally weighted in quantity < 1.5 g	0.001g /0.01 %		
Readability (d) for originally weighted in quantity > 1.5 g	0.001g /0.001 %		
Heating methods	<ul style="list-style-type: none"> • Standard • Fast • Step-by-step (freely selectable time / temperature steps) • Soft 		
Repeatability for originally weighted in quantity 2 g	0.5 %		
Repeatability for originally weighted in quantity 0.35 oz	0.02 %		
Repeatability in weighing mode (= standard deviation)	0.001g		
Recommended adjustment weight, not added (class)	50g (F2)		
Ambient conditions	<ul style="list-style-type: none"> • +15°C....+40°C ambient temperature • max 80% air humidity non-condensing 		

Shutoff criterion	<ul style="list-style-type: none"> • Automatic 1 (shutoff during change of weighing value < 1mg within 20s) • Automatic 2 (shutoff during change of weighing value < 1mg within 50s) • Automatic 3 (shutoff during change of weighing value < 1mg within 120s) • Automatic 4 (shutoff during change of weighing value < 1mg within 180s) • Automatic 5 (shutoff during change of weighing value < 1mg within 240s) • User-defined • User-defined 2 • Test • Manual • Time-controlled (1 min – 9h 59 min)
Sample dishes included	10 (Ø 92 mm)
Display after drying (*SG = initial weight g)	Moisture [%] = loss of weight (GV) from SG* 0 – 100 % Dry mass [%] = residual weight (RG) from SG* 100 – 0 % ATRO [%] [(SG – RG) : RG] x 100% 0 – 999 % Residual weight [g] (RG) Absolute value in [g] Display switchable at any time
Interface /RS232	Printout provided in selected language
Dimensions	Case 210 x 335 x 158 mm
	Available drying chamber 120 x 120 x 20 mm
Net weight	6 kg
Electric Supply	110-230VAC / 50-60Hz

1.1 Dimensions

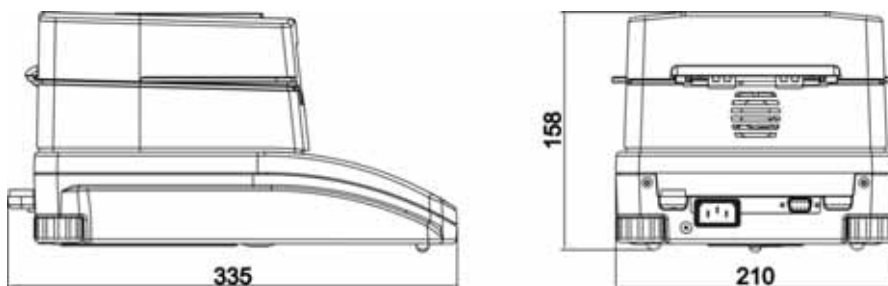

2 Declaration of conformity



KERN & Sohn GmbH

D-72322 Balingen-Frommern

Postfach 4052

E-Mail: info@kern-sohn.de

Tel: 0049-[0]7433- 9933-0

Fax: 0049-[0]7433-9933-149

Internet: www.kern-sohn.de

Konformitätserklärung

EC-Konformitätserklärung
EC- Déclaration de conformité
EC-Dichiarazione di conformità
EC- Declaração de conformidade
EC-Deklaracja zgodności

EC-Declaration of -Conformity
EC-Declaración de Conformidad
EC-Conformiteitverklaring
EC- Prohlášení o shode
EC-Заявление о соответствии

D	Konformitäts- erklärung	Wir erklären hiermit, dass das Produkt, auf das sich diese Erklärung bezieht, mit den nachstehenden Normen übereinstimmt.
GB	Declaration of conformity	We hereby declare that the product to which this declaration refers conforms with the following standards.
CZ	Prohlášení o shode	Tímto prohlašujeme, že výrobek, kterého se toto prohlášení týká, je v souladu s níže uvedenými normami.
E	Declaración de conformidad	Manifetamos en la presente que el producto al que se refiere esta declaración está de acuerdo con las normas siguientes
F	Déclaration de conformité	Nous déclarons avec cela responsabilité que le produit, auquel se rapporte la présente déclaration, est conforme aux normes citées ci-après.
I	Dichiarazione di conformità	Dichiariamo con ciò che il prodotto al quale la presente dichiarazione si riferisce è conforme alle norme di seguito citate.
NL	Conformiteit- verklaring	Wij verklaren hiermede dat het product, waarop deze verklaring betrekking heeft, met de hierna vermelde normen overeenstemt.
P	Declaração de conformidade	Declaramos por meio da presente que o produto no qual se refere esta declaração, corresponde às normas seguintes.
PL	Deklaracja zgodności	Niniejszym oświadczamy, że produkt, którego niniejsze oświadczenie dotyczy, jest zgodny z poniższymi normami.
RUS	Заявление о соответствии	Мы заявляем, что продукт, к которому относится данная декларация, соответствует перечисленным ниже нормам.

Electronic Balance: KERN MLS...N

Mark applied	EU Directive	Standards
CE	2004/108/EC EMC	EN 55022 : 2000 EN 61326-1: 2006
	2006/95/EC Low Voltage	EN 61010-1:2004

Date: 26.02.2008

Signature: _____

Gottl. KERN & Sohn GmbH
Management

Gottl. KERN & Sohn GmbH, Ziegelei 1, D-72336 Balingen, Tel. +49-[0]7433/9933-0, Fax +49-[0]7433/9933-149

3 Basic Information (General)

3.1 Proper use

The device purchased by you is designed for a fast and reliable determination of material moisture in liquid, porous and solid materials by applying the method of thermogravimetrics.

3.2 Improper Use

Impacts and overloading exceeding the stated maximum load (max) of the device, minus a possibly existing tare load, must be strictly avoided.

Balance may be damaged by this.

Never operate device in explosive environment. The serial version is not explosion protected.

The structure of the balance may not be modified. This may lead to incorrect weighing results, safety-related faults and destruction of the balance.

The balance may only be used according to the described conditions. Other areas of use must be released by KERN in writing.

3.3 Danger Information

Individual parts of the case (e. g. the ventilation grids) may heat up considerably during operation. For this reason, please touch the device only at the designated handles.

Sample materials developing aggressive vapours (e. g. acids) may cause corrosion problems on some parts of the device. The moisture meters should mainly be used for drying aqueous substances. Explosion prone, flammable samples must not be analysed using the moisture meter.

- Do not open or touch drying chambers during the drying process as the device develops very high temperatures.
- Do not place combustible materials on, under or next to the device.
- Ensure that there is sufficient empty space around the device in order to prevent heat accumulation (distance to device 20 cm, above it 1m).
- Do not use the moisture meter for analysing explosion prone, easily flammable samples.
- Do not operate the moisture meter in explosion prone environments.
- Sample materials emitting toxic substances must be dried with a special extraction system in place. Create an environment that prevents the inhalation of vapours hazardous to health.
- Make sure that liquids do not get in contact with the interior of the device or the connections at the rear of the device.

If you spill liquid on the device, disconnect it immediately.

Afterwards do not operate the moisture meter and have it checked by a competent KERN stockist before any further use.

3.4 Warranty

Loss of warranty due to

- Our conditions in the operation manual are ignored
- The appliance is used outside the described uses
- The appliance is modified or opened
- mechanical damage and damage caused by media, liquids, natural wear and tear
- The appliance is improperly set up or incorrectly electrically connected
- The measuring system is overloaded

3.5 Monitoring of Test Resources

In the framework of quality assurance the measuring-related properties of the balance and, if applicable, the testing weight, must be checked regularly. The responsible user must define a suitable interval as well as type and scope of this test. Information is available on KERN's home page (www.kern-sohn.com) with regard to the monitoring of balance test substances and the test weights required for this. In KERN's accredited DKD calibration laboratory test weights and balances may be calibrated (return to the national standard) fast and at moderate cost.

4 Basic Safety Precautions

4.1 Pay attention to the instructions in the Operation Manual

Carefully read this operation manual before setup and commissioning, even if you are already familiar with KERN balances.

4.2 Personnel training

The appliance may only be operated and maintained by trained personnel.

5 Transportation & Storage

5.1 Testing upon acceptance

When receiving the appliance, please check packaging immediately, and the appliance itself when unpacking for possible visible damage.

5.2 Packaging

Keep all parts of the original packaging in case you need to return the appliance.

Only use original packaging for returning.

Before sending, disconnect all connected cables and loose/movable parts.

Attach possibly existing transport safeguards. Secure all parts, e.g. weighing plate, power unit etc., to prevent slipping and damage.

6 Unpacking, Setup and Commissioning

6.1 Installation Site, Location of Use

The unit is designed to achieve reliable weighing results under normal conditions of use.

You will work accurately and fast, if you select the right location for your balance.

Therefore, observe the following for the installation site:

- Place the device on a firm, level surface;
- Avoid extreme heat as well as temperature fluctuation caused by installing next to a radiator or in the direct sunlight;
- Protect the device against direct draughts due to open windows and doors;
- Avoid jarring during weighing;
- Protect the appliance against high humidity, vapours and dust;
- Do not expose the device to extreme dampness for longer periods of time. Non-permitted condensation (condensation of air humidity on the appliance) may occur if a cold appliance is taken to a considerably warmer environment. In this case, acclimatize the disconnected appliance for ca. 2 hours at room temperature.
- Avoid static charging of the material to be weighed, weighing container and windshield.

If electro-magnetic fields or static charge occur, or if the power supply is unstable major deviations on the display (incorrect weighing results) are possible. In that case, the location must be changed.

6.2 Unpacking and erection

Take the moisture meter carefully out of its packaging, remove the plastic jacket and install it at the designated work space.

The moisture meter is supplied part-assembled. Control whether the delivery is complete immediately after unpacking the individual parts and assemble the separate component parts according to the enclosed diagram.

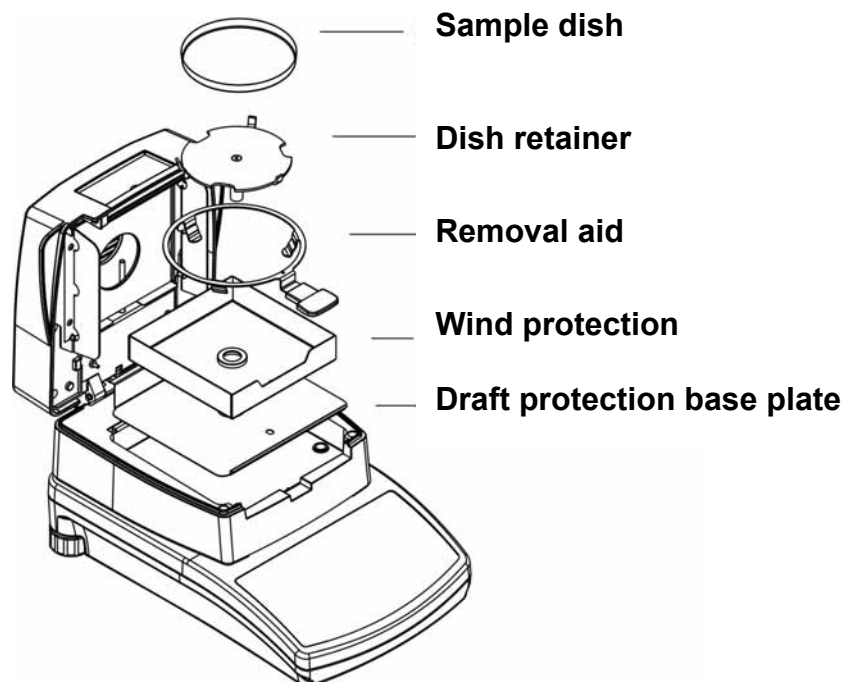

Put on the dish retainer carefully, ensuring correct positioning:

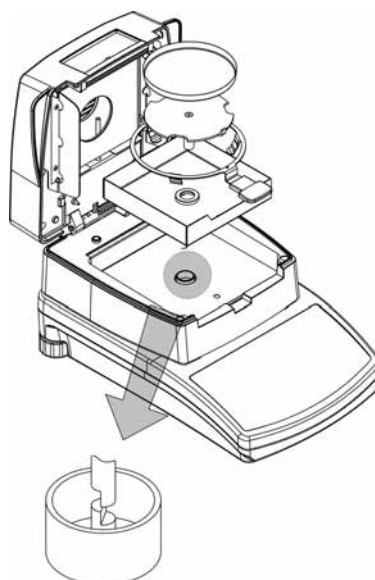

Level balance with foot screws until the air bubble of the water balance is in the prescribed circle

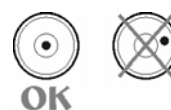

6.2.1 Scope of delivery

Serial accessories:

- Scales with moisture meter cap
- Dish retainer
- Removal aid
- 10 sample dishes
- Power cable
- Wind protection
- Operating Manual

6.3 Mains connection

Power supply is provided via the supplied mains cable.

Check, whether the voltage acceptance on the scales is set correctly. Do not connect the scales to the power grid unless the information on the scales (sticker) matches the local mains voltage.

Important:

Does the labelling (220 V 50Hz) match the local mains voltage?

- Do not connect if mains voltages are different!
- If matching, connect the scales.

The moisture meter must be connected to a standard socket with earth terminal. Do not eliminate the protective effect by using an extension lead without earth terminal. For power supplies from power grids without earth terminals call a specialist to establish equivalent protection according to the relevant installation regulations.

6.3.1 Switch on the unit

Press the **ON/OFF** key. The unit will carry out a self-test. The device is ready for measuring as soon as 0.000 g appears on the weighing display. If the display deviates from zero, operate the **TARE** key.

6.4 Connection of peripheral devices

Before connecting or disconnecting of additional devices (printer, PC) to the data interface, always disconnect the balance from the power supply.

With your balance, only use accessories and peripheral devices by KERN, as they are ideally tuned to your balance.

6.5 Initial Commissioning

In order to obtain exact results with the electronic balances, your balance must have reached the operating temperature (see warming up time chap. 1).









During this warming up time the balance must be connected to the power supply (mains, accumulator or battery).

The accuracy of the balance depends on the local acceleration of gravity.

Strictly observe hints in chapter Adjustment.

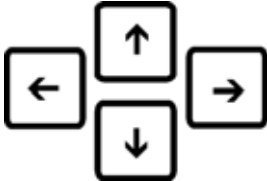























6.6 Keyboard overview



Key	Function
	<ul style="list-style-type: none"> Switch machine on/off
	<ul style="list-style-type: none"> Change display during drying process
	<ul style="list-style-type: none"> Start/Stop drying
	<ul style="list-style-type: none"> Cancel an entry Leave menu
	<ul style="list-style-type: none"> Arrow keys for navigation in menu Change the value of a parameter
	<ul style="list-style-type: none"> Data export to external device Confirm/save settings
	<ul style="list-style-type: none"> Tara key scales zero digits
	<ul style="list-style-type: none"> Invoke user menu (drying parameter setting)
	<ul style="list-style-type: none"> Invoke user menu

6.6.1 Operating the scales using PS keyboard

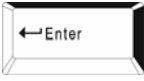
Using a PS keyboard will help you to enter numbers and texts faster and easier.

						Balance keyboard
						PS keyboard
						Balance keyboard
						PS keyboard

7 Menu

The menu is arranged in a user and operator menu.

Activate the user menu via the **F** key, the operator menu via the **MENU** button.



The table below shows the functions of the user menu.

User menu (F-key)	
P1 Calibration	
P1 01 external calibration	
P1 02 user calibration	
P1 03 calibration test	
P1 04 temperature calibration	
P1 05 protocol printout	yes/no
P2 GLP	
P2 01 user	
P2 02 project	
P2 03 printout time	yes/no
P2 04 printout date	yes/no
P2 05 user printout	yes/no
P2 06 project printout	yes/no
P2 07 Id printout	yes/no
P2 08 cal. printout	yes/no

P3	Date/time	
	P3 01 date format	M/T/J; T/M/J
	P3 02 clock time format	12 h; 24 h
	P3 03 time	
	P3 04 date	
	P3 05 display time	yes/no
	P3 06 display date	yes/no
P4	Display	
	P4 01 filter	Extra slow; slow; standard; fast; extra fast
	P4 02 auto zero	yes/no
	P4 03 temperature	yes/no
	P4 04 negative	yes/no
P5	RS-232	
	P5 01 Baud speed	2400; 4800; 9600; 19200
	P5 02 parity	None, even, odd
	P5 03 data bits	7 bits; 8 bits
	P5 04 stop bits	1 bit; 2 bits
	P5 05 handshake	none; XON/XOFF; RTS/CTS
	P5 06 printout for style	yes/no
	P5 07 printer	Epson/Standard
P6	Version	
	P6 01 printout no.	
	P6 02 header no.	
	P6 03.line no.	
	P6 04 footnote no.	
	P6 05 1. printout start	
	P6 06 1. printout stop	
	P6 13 1. text	
	P6 14 2. text	
P7	Other	
	P7 01 password	None or 8 characters
	P7 02 program library	0 – off; 1 - on
	P7 03 signal	0 – off; 1 - on
	P7 04 language	English, German
	P7 05 light	0 – off; 1 - on
	P7 06 contrast	
	P7 07 scales no.	
	P7 08 program no.	
	P7 09 parameter printout	
	P7 10 parameter receipt	
	P7 11 Set ID	
	P7 12 auto. ID printout	yes/no

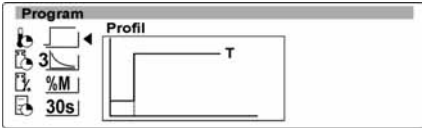
7.1 Navigation in the menu:

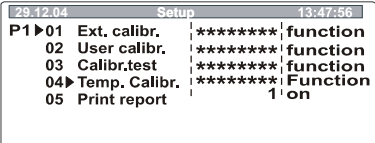
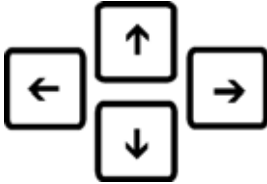
Operation/display:	Description:
	<p>The overview for the Operator Menu appears</p>
<p>Either P7 02 program library “on” (See chpt. 9.2.1)</p> <div data-bbox="587 607 1002 763" style="border: 1px solid black; padding: 5px; margin: 10px auto; width: fit-content;"> <pre> Program library P00 * P01 Program 1 P02 Program 2 P03 Program 3 P04 Program 4 P05 Program 5 P06 Program 6 </pre> </div> <p>Up to 100 different drying processes can be stored in the device. Simply invoke and start the finished processes from the library.</p> <p>or P7 02 program library “off” (See chpt. 9.1.1)</p> <div data-bbox="584 958 1007 1084" style="border: 1px solid black; padding: 5px; margin: 10px auto; width: fit-content;">  </div>	
<p>Press the Esc-key and exit the overview without changing any settings</p>	
<div data-bbox="368 1218 451 1274" style="border: 1px solid black; padding: 2px; margin: 0 auto; width: 40px; text-align: center;">F</div> <div data-bbox="188 1330 632 1550" style="border: 1px solid black; padding: 5px; margin: 10px auto; width: fit-content;"> <pre> 29.12.04 Setup 13:47:56 P1▶ Calibration P2 GLP P3 Date/Time P4 Redout P5 RS-232 P6 Printouts P7 Globals </pre> </div>	<p>The overview for the User Menu appears</p>
<p>Either press the Esc-key twice and exit the overview without changing any settings or</p> <p>or</p> <p>change settings in the menu as follows.</p>	
<div data-bbox="325 1854 497 1939" style="display: flex; justify-content: center; gap: 10px;"> <div style="border: 1px solid black; padding: 5px; text-align: center;">↓</div> <div style="border: 1px solid black; padding: 5px; text-align: center;">↑</div> </div>	<p>Menu selection via arrow keys:</p> <p>Use the cursor (▶) to select your setting. Use the ↓ key to move the cursor (▶) down, the ↑ key to move it up</p>

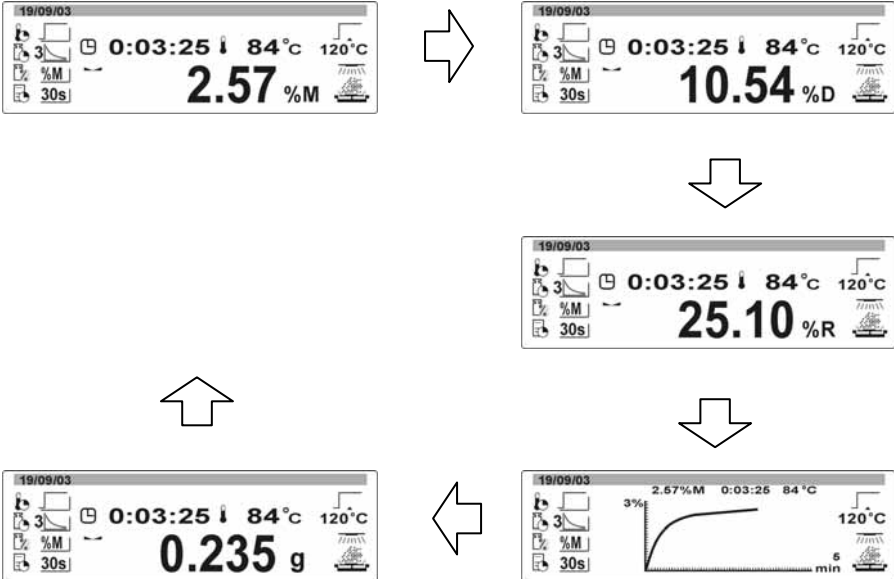
	<p>Confirm the setting by pressing the →-key; the submenu appears on the display</p>
	<p>How to change functions and parameters Use the arrow keys to move within and enter into the menu:</p> <p>To select parameters in a function or to increase/decrease the value of a digit or number press the ↓- and ↑-key.</p> <p>To shift to the right or left by one menu item press the ←- and →-key.</p>
	<p>Confirm your entries</p>
	<p>Change display during drying process There are 5 different options to display the measured result; switching is achieved by pressing the M-key.</p> <ol style="list-style-type: none"> 1. Drying time 2. Temperature in heating chamber 3. Heating profiles 4. Result in %M; %D; %R – diagram 5. Weight loss in [g]
	



Any changes made will be saved when returning to weighing mode by using the following saving procedure:



Actuate **Esc** key again, a message will inquire whether you want to save the changes you made.

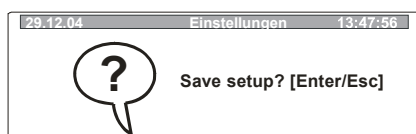

either



To save your changes, press the **PRINT**-key.

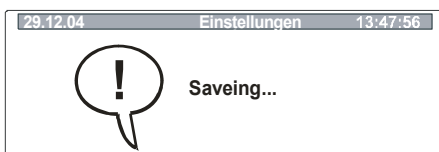

or



If you do not wish to save your changes, press the **Esc**-key



8 User menu

Press the F-key; the main menu appears:

	<ol style="list-style-type: none"> 1. Menu number (P1 - P9) 2. Menu designation 3. Cursor (▶) indicates the current menu item
--	--

Use the cursor (▶) to select your setting.

Use the ↓ key to move the cursor (▶) down, the ↑-key to move it up Press the →-key; the submenu appears:

	<ol style="list-style-type: none"> 1. Menu number (P1 - P9) 2. Submenu number and name 3. Parameter value or ***** if menu item is stored as a function 4. Description of function 5. Cursor (▶) shows the current menu item (e.g. P1). 6. Cursor (▶) shows the current setting (e.g. 06). 7. Status 8. Use the arrow key to modify the parameter value, the active parameter blinks.
--	---

8.1 P1 Calibration (adjustment)

As the acceleration value due to gravity is not the same at every location on earth, each balance must be coordinated - in compliance with the underlying physical weighing principle - to the existing acceleration due to gravity at its place of location (only if the balance has not already been adjusted to the location in the factory). This adjustment process must be carried out for the first commissioning, after each change of location as well as in case of fluctuating environment temperature. To receive accurate measuring values it is also recommended to adjust the balance periodically in weighing operation.

Procedure when adjusting:







Calibration should be carried out by using a recommended calibration weight.

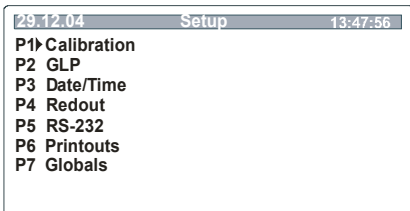
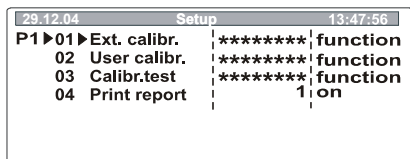
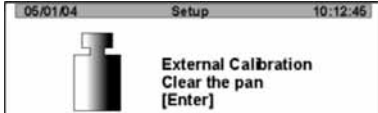

(See chpt. 1 "Technical specifications"):

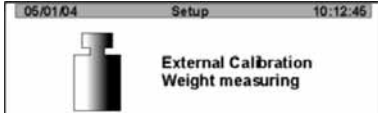

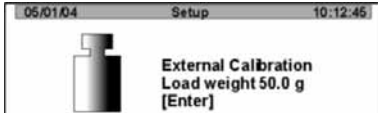
Observe stable environmental conditions. A warm-up time of 2 hours is necessary for stabilisation.

Note!

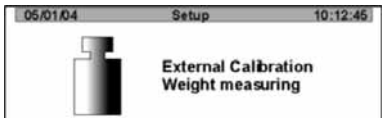
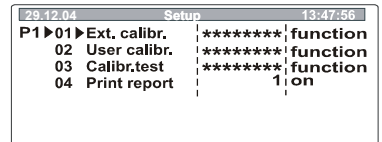
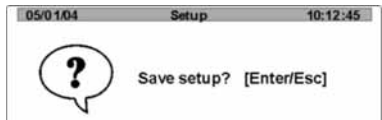
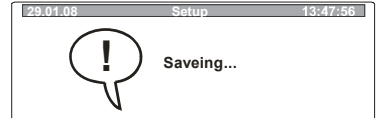
Sample dishes must be in place. During the adjustment process no objects should be on the sample plate.

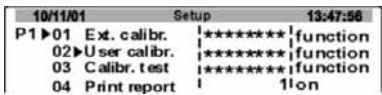
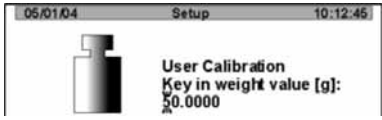
Operation	Display
<p>Call up menu item "P1 Calibration" (see chapt. 7.1)</p> <p>Press → button</p>	 <p>29.12.04 Setup 13:47:56 P1▶ Calibration P2 GLP P3 Date/Time P4 Redout P5 RS-232 P6 Printouts P7 Globals</p>
<h3>01 Adjustment using external weight – Ext. Cal</h3>	
<p>Press → button</p> <p>Ensure that there are no objects on the sample plate.</p>	 <p>29.12.04 Setup 13:47:56 P1▶01▶Ext. calibr. ***** function 02 User calibr. ***** function 03 Calibr.test ***** function 04 Print report 1 on</p>  <p>05/01/04 Setup 10:12:45  External Calibration Clear the pan [Enter]</p>
<p>Press PRINT key, on the display appears the weight value of the adjusting weight.</p>	 <p>05/01/04 Setup 10:12:45  External Calibration Weight measuring</p>  <p>05/01/04 Setup 10:12:45  External Calibration Load weight 50.0 g [Enter]</p>

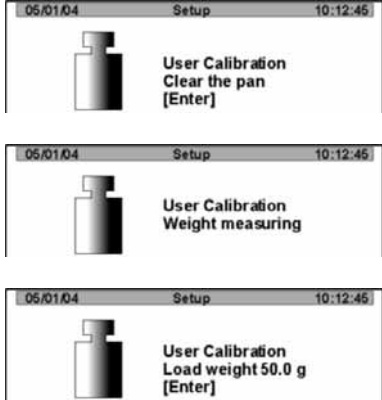
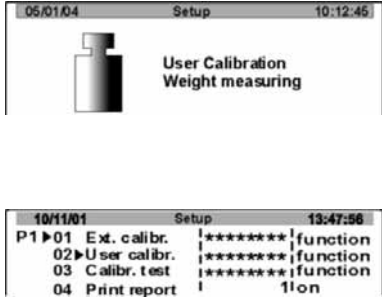
<p>Place the adjustment weight in the centre of the sample dish, then press the PRINT key. If the adjustment was successful, this will be followed by automatic reset to the menu.</p> <p>The ESC key may be used to cancel the adjustment. Errors during adjustment or the use of an incorrect adjusting weight will result in an error message. Repeat adjustment.</p>	 
<p>Return to weighing mode:</p> <p>Press the ESC-key repeatedly until the query "SAVE?" appears.</p> <p>Confirm query by pressing the PRINT-key or reject it by pressing the ESC-key.</p>	  
<p>02 External adjustment using freely selectable weight – user Cal</p>	
<p>To select "02 User Cal.", use the arrow keys (↓ ↑)</p>	
<p>Press →-key, on the display appears the weight value of the adjusting weight. The first digit of the displayed value is flashing. Now you can make changes pressing the arrow keys.</p> <p>To change the number value, press the ↓ ↑ keys.</p> <p>To select a digit to the left/right, press the ← → keys.</p> <p>Confirm the entered weight value by pressing the PRINT-key.</p>	

<p>Ensure that there are no objects on the weighing plate. Press the PRINT key.</p> <p>In the display there appears the value of the adjustment weight.</p>	
<p>Place the required adjustment weight in the centre of the sample dish, then press the PRINT key. If the adjustment was successful, this will be followed by automatic reset to the menu.</p> <p>Take away adjustment weight.</p> <p>The ESC key may be used to cancel the adjustment.</p> <p>Errors during adjustment or the use of an incorrect adjusting weight will result in an error message.</p> <p>Repeat adjustment.</p>	
<p>Return to weighing mode:</p> <p>Press the ESC-key repeatedly until the query "SAVE?" appears.</p> <p>Confirm query by pressing the PRINT-key or reject it by pressing the ESC-key.</p>	
<p>We recommend:</p> <p>Carry out all adjustments as close as possible to the maximum load of the balance.</p> <p>Info about test weights can be found on the Internet at: http://www.kern-sohn.com</p>	

03 Calibration test

This is used to determine the deviation from the last adjustment. This is only a check, i.e. no values are changed.

Press the arrow keys (↓ ↑), to select “03 Cal. test“.

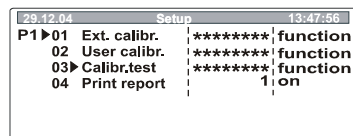

Press → button

Ensure that there are no objects on the weighing plate.

Press **PRINT** key, on the display appears the weight value of the required adjusting weight.

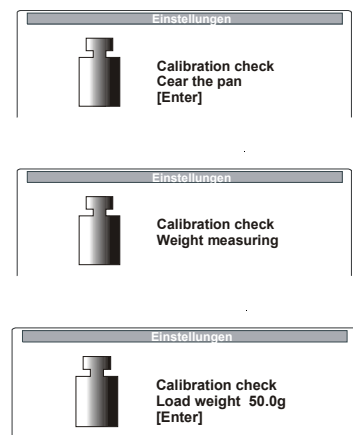

Then place the required adjustment weight in the centre of the sample dish, press the **PRINT** -key.

The result of the calibration test is shown on the display.

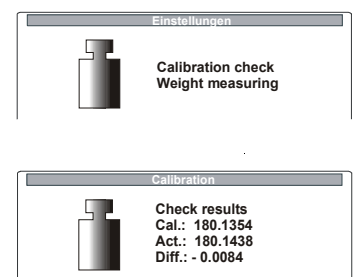

Take away adjustment weight. To return to the menu or weighing mode, press the **ESC**-key several times.

Return to weighing mode:
Press the **ESC**-key repeatedly until the query “**SAVE?**“ appears. Confirm query by pressing the **PRINT**-key or reject it by pressing the **ESC**-key.

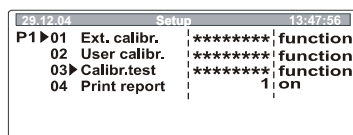

04 Temperature adjustment

We recommend checking the temperature value of the device from time to time. Before you do this, allow the device to cool down for at least 3 hours after the last heating phase. Push the probe into the designated hole in the disk. Push the probe as closely as possible to the thermal sensor of the MLS. The temperature is measured at two points and it is possible to correct it at both temperature points.

1. Procedure using temperature calibration set MLB-A11

Select by using the arrow keys (↓ ↑) „04 Temp.cal“

Press → key

Temperature calibration starts.

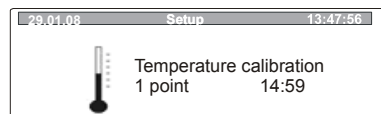
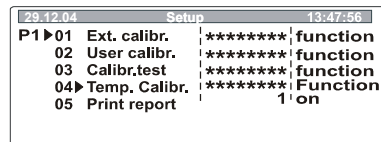

Temperature calibration of first point will take 14.59 min after which you will hear an acoustic signal.

Now you can correct the temperature value (e. g. 25/24), as required, by using the arrow keys (↓ ↑) .

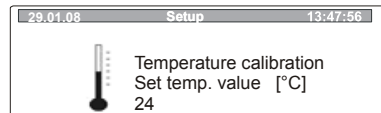
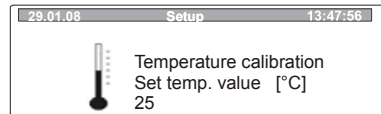
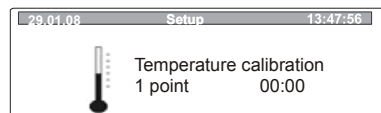

To import the temperature values, press the **PRINT**-key; temperature calibration for the second point will be started.

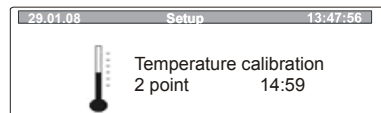

Temperature calibration of first point will take 14.59 min after which you will hear an acoustic signal.

You can now correct the temperature value (e.g. 120/122), as required by using the arrow keys (↓ ↑).

To import the temperature values, press the **PRINT**-key.

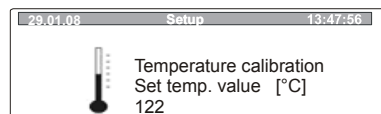
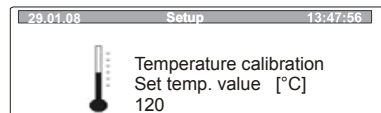
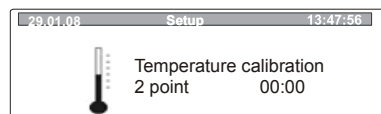

Return to weighing mode:

Press the **ESC**-key repeatedly until the query "SAVE?" appears. Confirm query by pressing the **PRINT**-key or reject it by pressing the **ESC**-key.

2. Procedure using AUTO temperature calibration set MLS-A02

- **Temperature calibration**

If merely the temperature present in the MLS is supposed to be measured, follow the procedure described under “temperature adjustment” without connection to the RS 232 interface.

- **Temperature adjustment**

Temperature is measured at two points and automatically corrected at these two temperature points.

To carry out adjustments to the temperature, the following settings are required on the MLS-A02:

Turn on device using the  key. The unit will carry out a self-test. The display shows all symbols:

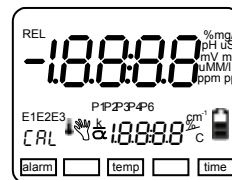







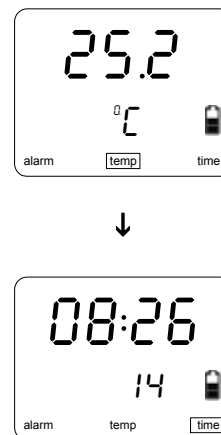



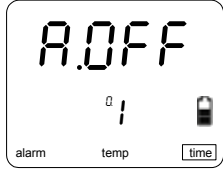
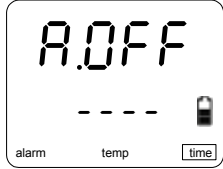

Information:

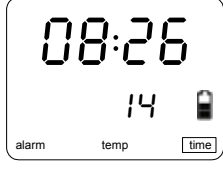
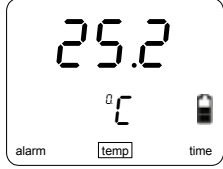
Disable the automatic shutoff function for temperature calibration as follows:

Press  key repeatedly until time display appears



Press  key repeatedly until *A.OFF* and the current shutoff time appears.

<p>To disable, set by pressing the keys  or  set the shutoff time to - - - - .</p>	 
<p>Press  button The auto OFF function is disabled.</p> <p>Press the  key repeatedly until the temperature display appears.</p>	 ↓ 
<p>In temperature measuring mode, press the  key and keep holding it until the following message is flashing.</p>	<p>24.55 ↓ 12.23 ↓ 3.22 ↓ n0.16</p>
<p>Press the  key again, - - - - appears</p>	<p>- - - -</p>
<p>Press  button</p>	<p>SEr OFF</p>
<p>Press  button</p>	<p>Prt ON</p>
<p>Press  button</p>	<p>ALL ON</p>
<p>Press the  key repeatedly until - - - - appears</p>	<p>- - - -</p>
<p>Press the  key until the current temperature is displayed</p>	<p>24.55 °C</p>

The following settings on the MLS are required for temperature adjustment:

When using the temperature calibration set MLS-A02, set the baud rate for the MLS to 9600 as follows:

Turn on moisture meter

Press **F** key

Press the arrow keys (↓ ↑), to select “**P5 RS-232**”

Press → button

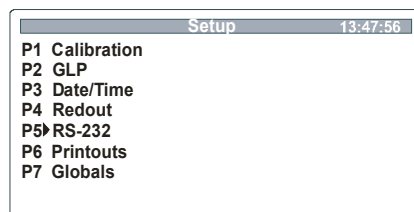

Press the arrow keys (↓ ↑), to select “**01 Baud rate**”.

Press the → key; current menu item flashes
Set M to a baud rate of 9600, using arrow keys (↓ ↑)

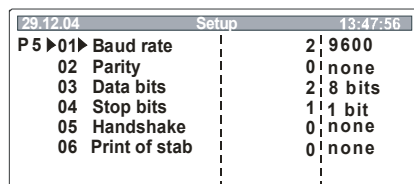

Confirm by pressing the **PRINT** key

Press down and hold the **ESC**-key until the balance returns to the menu.

Press the arrow keys (↓ ↑), to select “**P1 Calibration**”

Press → button

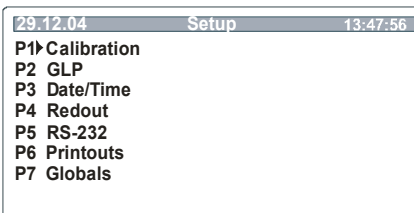

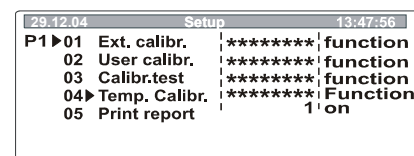

Select by using the arrow keys (↓ ↑)
„**04 Temp.cal**”

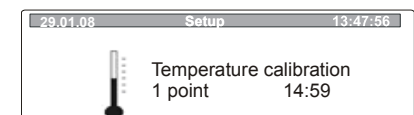

Press → button

This starts temperature calibration.

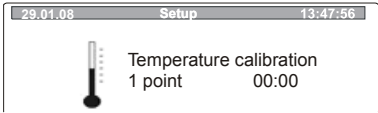
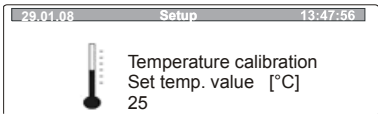
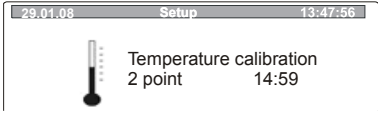
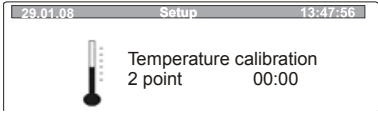
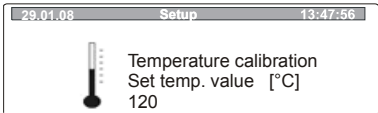

<p>Temperature calibration for the first point takes 14.59 min.</p> <p>The temperature value is corrected automatically.</p>	 
<p>Next, temperature calibration for the second point will start automatically.</p>	
<p>Temperature calibration for the second point takes 14.59 min.</p> <p>The temperature value will be corrected and saved automatically.</p> <p>The balance returns automatically into weighing mode.</p>	   

05 Report printout

This menu point is used to enable the function for printing your adjustment data.

Press the arrow keys (↓ ↑), to select “05 Print report”

Press the →-key; the current menu item blinks.

Press the arrow keys (↓ ↑), to select the desired settings:

- 0 Report printout disabled
- 1 Report printout enabled

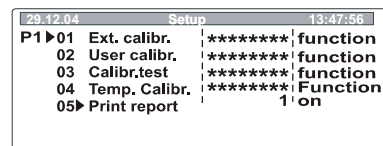

Confirm by pressing the **PRINT** key.

Return to weighing mode:

Press the **ESC**-key repeatedly until the query “**SAVE?**” appears. Confirm query by pressing the **PRINT**-key or reject it by pressing the **ESC**-key.

If **Report printout** is enabled you will receive a protocol for your adjustment data after each adjustment. The content of this printout depends on the data defined in **P2 GLP** (See chpt. 8.2)

```

***Protocol of external calibration***

Person in charge of calibration:    external

Diff..      :      -0.0624 g

Signature.....
    
```

8.2 P2 GLP (Good laboratory practice)

Quality assurance systems require printouts of weighing results as well as of correct adjustment of the balance stating date and time and balance identification. The easiest way is to have a printer connected.

Definition of a standard log:

Operation	Display
<p>Call up menu item "P1 Calibration" (see chapt. 7.1)</p> <p>Press → button</p>	
01 User	
<p>Press the arrow keys (↓ ↑), to select "01 User".</p> <p>Press → button</p> <p>Enter user name or number (max. 8 characters) via arrow keys (See chpt. 7.1); relevant enabled digit flashes</p>	
<p>Confirm by pressing the PRINT key</p>	
02 Project	
<p>Press the arrow keys (↓ ↑), to select "02 Project".</p> <p>Press → button</p> <p>Enter project name or number (max. 8 characters) via arrow keys (See chpt. 7.1); relevant enabled digit flashes</p>	
<p>Confirm by pressing the PRINT key</p>	
<p>All other settings (03 - 08) are executed analoguely</p>	

All settings that are supposed to be printed must be activated with "1 / yes"

Example 1:

Adjustment

P2	03	Printout time	1	yes
P2	04	Printout date	1	yes
P2	05	User printout	1	yes
P2	06	Project printout	1	yes
P2	07	ID-printout	1	yes
P2	08	Cal. printout	1	yes

printout

Date	: 18.01.05
Time	: 10:41:05
User	: Mustermann
Project	: AB/007
Balance no.	: WL 041078

18.01.08	07:48
Calibration	
Deviation :	0.0001 g

130,0500 g	

Example 2:

Adjustment

P2	03	Printout time	0	no
P2	04	Printout date	1	yes
P2	05	User printout	1	yes
P2	06	Project printout	0	no
P2	07	ID-printout	1	yes
P2	08	Cal. printout	0	no

printout

Date:	22/10/2008
User:	Mustermann
Balance no.:	10

13.0521 g	

8.2.1 P3 Date/time

Under this menu item you can set output and format of time and date.

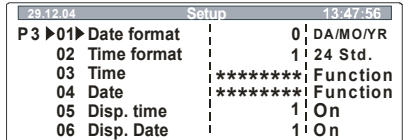
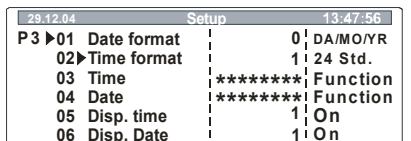
Operation	Display
<p>Call up menu item "P3 Date/time" (see chap. 7.1)</p> <p>Press → button</p>	 <pre> 29.12.04 Setup 13:47:56 P1 Calibration P2 GLP P3▶Date/Time P4 Redout P5 RS-232 P6 Printouts P7 Globals </pre>
<h3>01 Date format</h3>	
<p>Press the arrow keys (↓ ↑), to select "01 Date Format".</p> <p>Press → button</p> <p>Press the arrow keys (↓ ↑), to select among the settings below:</p> <p style="padding-left: 40px;"> 1 Month/Day/Year 0 Day/Month/Year </p>	 <pre> 29.12.04 Setup 13:47:56 P3 ▶01 Date format 0 DA/MO/YR 02 Time format 1 24 Std. 03 Time *****! Function 04 Date *****! Function 05 Disp. time 1 On 06 Disp. Date 1 On </pre>
<p>Confirm by pressing the PRINT key</p>	
<h3>02 Time format</h3>	
<p>Press the arrow keys (↓ ↑), to select "02 Time Format".</p> <p>Press → button</p> <p>Press the arrow keys (↓ ↑), to select among the settings below:</p> <p style="padding-left: 40px;"> 0 24 hours 1 12 hours (PM/AM) </p>	 <pre> 29.12.04 Setup 13:47:56 P3 ▶01 Date format 0 DA/MO/YR 02▶Time format 1 24 Std. 03 Time *****! Function 04 Date *****! Function 05 Disp. time 1 On 06 Disp. Date 1 On </pre>
<p>Confirm by pressing the PRINT key</p>	

03 Time

Press the arrow keys (↓ ↑), to select “03 Time”.

Press → button

Press the arrow keys (↓ ↑), to select the desired settings:

Press → button

Press the arrow keys (↓ ↑), to trigger your selection.

Press the →-key, to confirm the selected setting (e.g. hours), the current menu item flashes

To change the number value, press the ↓ ↑ keys. Press the ← → keys, to select the digit on the left/right (the relevant current digit flashes). Confirm input by pressing the **PRINT** key.

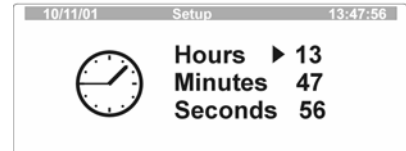
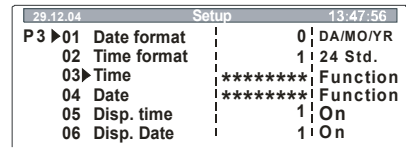

To change minutes and seconds proceed in the same way.

To confirm, press the **PRINT**-key; the scales display the time you selected.

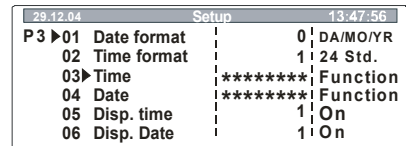

04 Date

Press the arrow keys (↓ ↑), to select “04 Date”.

Press → button

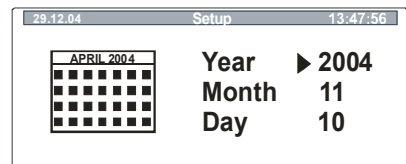
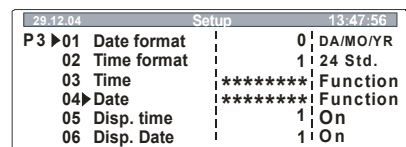

All other settings are made in the same way as time (03 Time).

02 Auto zero

Press the arrow keys (↓ ↑), to select “02 Auto zero”.

Press the →-key; the current menu item blinks

Press the arrow keys (↓ ↑), to select among the settings below:

- 0 Deviations from the Zero display are **not** automatically tared.
- 1 Deviations from the Zero display are automatically tared.

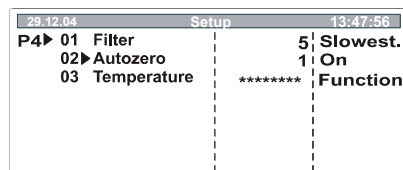

Confirm by pressing the **PRINT** key

03 Temperature

Press the arrow keys (↓ ↑), to select “03 Temperature”.

Press the →- key; sample room temperature is displayed.

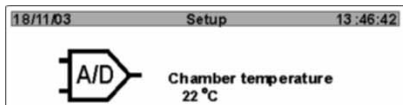
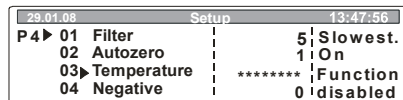

To return to menu, press the **ESC**-key

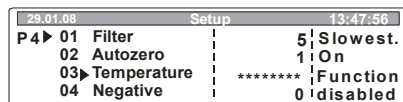

04 Negative

Press the arrow keys (↓ ↑) to select “04 Negative”.

Press the → -key; the current menu item blinks

Press the arrow keys (↓ ↑) to reverse the colour setting of the display.

- 0 blocked
- 1 active

Confirm by pressing the **PRINT** key

Return to weighing mode:

Press the **ESC**-key repeatedly until the query “**SAVE?**” appears. Confirm query by pressing the **PRINT**-key or reject it by pressing the **ESC**-key.

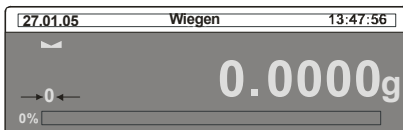
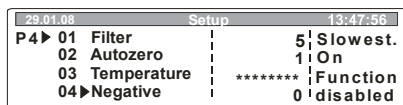

8.2.3 P5 RS-232

In this menu item you can save your settings for the interface.

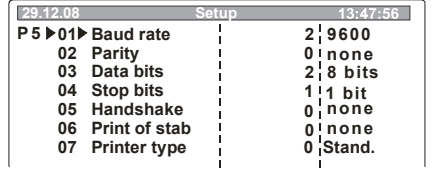
Operation	Display
<p>Call up menu item "P5 RS-232" (see chapt. 7.1)</p> <p>Press → button</p>	 <pre> Setup 13:47:56 P1 Calibration P2 GLP P3 Date/Time P4 Redout P5▶RS-232 P6 Printouts P7 Globals </pre>
<p>01 - 07</p>	
<p>Press the arrow keys (↓ ↑) to select your settings (01 – 07).</p> <p>Press the →-key; the current menu item blinks</p> <p>Use the arrow keys (see chapter 7.1) to save your settings</p>	 <pre> 29.12.08 Setup 13:47:56 P5▶01▶Baud rate 2 9600 02 Parity 0 none 03 Data bits 2 8 bits 04 Stop bits 1 1 bit 05 Handshake 0 none 06 Print of stab 0 none 07 Printer type 0 Stand. </pre>
<p>Confirm by pressing the PRINT key</p> <p>Return to weighing mode: Press the ESC-key repeatedly until the query "SAVE?" appears. Confirm query by pressing the PRINT-key or reject it by pressing the ESC-key.</p>	

8.2.4 P6 output

In this menu item you can select between 5 different types of data output:

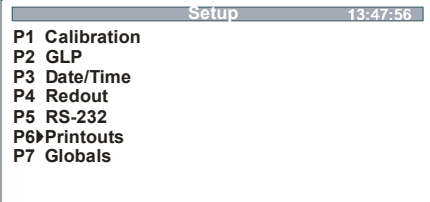
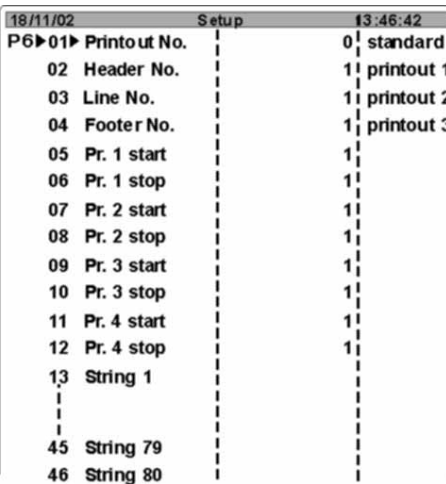
Operation	Display
<p>Call up menu item "P6 Output" (see chapt. 7.1)</p> <p>Press → button</p>	 <pre> Setup 13:47:56 P1 Calibration P2 GLP P3 Date/Time P4 Redout P5 RS-232 P6 Printouts P7 Globals </pre>
<p>01 Printout no.</p>	
<p>Press the arrow keys (↓ ↑) to select "01 printout no."</p> <p>Press the →-key; the current menu item blinks</p> <p>Press the arrow keys (↓ ↑), to select among the settings below:</p> <p>0 standard</p> <p>1 1. printout</p> <p>↓ ↓</p> <p>4 4. printout</p>	 <pre> 18/11/02 Setup 13:46:42 P6 01 Printout No. 0 standard 02 Header No. 1 printout 1 03 Line No. 1 printout 2 04 Footer No. 1 printout 3 05 Pr. 1 start 1 06 Pr. 1 stop 1 07 Pr. 2 start 1 08 Pr. 2 stop 1 09 Pr. 3 start 1 10 Pr. 3 stop 1 11 Pr. 4 start 1 12 Pr. 4 stop 1 13 String 1 45 String 79 46 String 80 </pre>
<p>Confirm by pressing the PRINT key</p>	

8.2.4.1 Standard data output (0 standard)

Data output is carried out by actuating the **PRINT**-key.

Definition of the log header is executed in menu item "**P2 GLP**".

Examples in weighing mode:

Date:	22/10/2004
Time:	13.04.23
User:	Mustermann
Project:	XW/456
	0.008 g

Date:	22/10/2004
Time:	13.16.49
User:	Mustermann
Project:	XW/456
Balance:	10
?	62.685 g *

*: ? = instable measuring value

Example in drying mode:

----- Start drying-----		
Program nb	: 1	} Header
Name	: Floar 100	
Profile	: Standard	
Dry temp.	: 120 °C	
Switch off	: Automatical 3	
Result	: Moisture contents - %M	
Printout int	: 30 s	
Target	: None	
T. coeficjent	: 0.00	
Start weight	: 9.993 g	
0:00:30	0.01 %M	} Measured values
0:01:00	0.02 %M	
0:01:30	0.03 %M	
Final mass	: 9.990 g	
Dry time	: 0:01:45	} Footers
Final result	: 0.03 %M	
----- End of drying procedure -----		

8.2.4.2 User defined data output (1st printout ↔ 4th printout)

Here you can define 4 different types of data output.

⇒ The content of the data output is defined as follows.

First line **1. Printout start - 0.1**, i.e. text begins at line 1 (1. Text)

Last line **1. Printout stop - 20**, i.e. text ends at line 20 (20. Text)

⇒ Text input per line is carried out via the arrow keys (see chapter 7.1) in the respective strings.

1. Text Start of text input
20. Text End of text input

During text input lines may overlap, e.g.:

1. Printout start - 1
1. Printout stop - 40
2. Printout start - 20
2. Printout stop - 40

Text input:

- Max. 640 characters
- 80 lines
- 8 characters per line

⇒ After each line confirm your text input using the **PRINT**-key.

⇒ After entering full text press the **ESC** –key; query appears, whether you want to save your entries.

⇒ Confirm by pressing the **PRINT**-key (See chpt. 7.1).

Apart from flow text (characters, numbers and numerals) the following variables are stored in the menu:

General variables	
%%	Printout of 1 character “%” (i.e. in order to print out 1 character %, two %% must be entered)
%N	Net weight
%d	Current date
%t	Current time
%i	Balance ID-no.
%r	Program no.
%P	Project number.
%U	User no.
%k	Date and time of last adjustment
%K	Type of last adjustment
%l	Deviation from last adjustment
%1	Code 1
%2	Code 2
%3	Code 3
%4	Code 4
%5	Code 5
%6	Code 6

Print related variables	
//	Printout of 1 character “/” (i.e. in order to print out 1 character /, two // must be entered)
c	CRLF (carriage return line feed) line beginning next line
r	CR (carriage return) line beginning
n	LF (line feed) next line
lt	tabulator
s	Next "Text"
∅	End of data input

Variables in drying mode	
%C	Temperature sample room
%M	Result - wet
%D	Result - dry
%R	Result – wet/dry
%N	Result
%C	Drying time
%S	Initial value sample
%E	Final value sample
%P	Parameter for drying process

Input of variables via arrow keys.

Example of text input in weighing mode:

Example 1: *Max mass can not exceed 11.250 g!*

Parameter No.	Text							
	1	2	3	4	5	6	7	8
20 Text 10	M	a	x		m	a	s	s
21 Text 11		c	a	n		n	o	t
22 Text 12		e	x	c	e	e	d	
23 Text 13	1	1	.	2	5	0		g
24 Text 14		!						
25 Text 15								

Example 2: *Kern & Sohn GmbH*

Date:

Time:

Weight:

*****Signature:.....*

**** current mode****

Parameter No.	Text							
	1	2	3	4	5	6	7	8
26 Text 16	K	e	r	n		&		S
27 Text 17	o	h	n		G	m	b	H
28 Text 18	\	c	D	a	t	u	m	:
29 Text 19	%	d	\	c	Z	e	i	t
30 Text 20	:	%	t	\	r	\	n	G
31 Text 21	e	w	i	c	h	t	:	%
32 Text 22	N	\	c	\	c	*	*	*
33 Text 23	*	*	U	n	t	e	r	s
34 Text 24	c	h	r	i	f	t	:	.
35 Text 25
36 Text 26	.	.	\	c	*	*	%	F
37 Text 27	*	*	*	\	c	\		

Example for text input in drying mode

Parameter selection:

- Header – 2. printout (menu item P6 01header no.)
- Measured value – 3. Printout (menu item P6 01 line no.)
- Footers – 4. Printout (menu item P6 01 footnote no.)

18/11/02		Setup	13:48:42
P6 01	Printout No.	0	standard
02	Header No.	2	printout 2
03	Line No.	3	printout 3
04	Footer No.	4	printout 4
05	Pr. 1 start	1	
06	Pr. 1 stop	1	
07	Pr. 2 start	10	
08	Pr. 2 stop	20	
09	Pr. 3 start	21	
10	Pr. 3 stop	22	
11	Pr. 4 start	23	
12	Pr. 4 stop	35	

2. printout	3. printout	4. printout
<pre> 22 String 10 :Drying_s 23 String 11 :start\cDa 24 String 12 :te:%d\cTi 25 String 13 :ime:%t\c 26 String 14 :Drying_p 27 String 15 :arameter 28 String 16 :s.\c\c%p 29 String 17 :\c\c\Sta 30 String 18 :rt_weigh 31 String 19 :t:%N\c\c 32 String 20 :\0----- </pre>	<pre> 33 String 21 :%C%M\c%N 34 String 22 :\c\0----- </pre>	<pre> 35 String 23 :Stop_well 36 String 24 :ght:%N\c 37 String 25 :Time_dry 38 String 26 :ing:%C\c 39 String 27 :\c\Final_ 40 String 28 :result:% 41 String 29 :M\c\cDry 42 String 30 :ing_stop 43 String 31 :\c\cSign 44 String 32 :ature:... 45 String 33 :..... 46 String 34 :..... 47 String 35 :\c\0----- </pre>
* string = Text		

Printout:

Start of the measurement		
Date	:	27:11:2003
Time	:	11:27
Drying parameters.		
Program number	:	3
Name	:	Floar 100
Profile	:	Standard
Dry temperature	:	120 °C
Switch off	:	Automatic 3
Result	:	Moisture contents %M
Printout int	:	30 s
Target	:	none
T. coeficjnt	:	0.00
Start weight	:	5.433 g
0:00:30	0.53 %M	5.031 g
0:01:00	2.02 %M	4.636 g
0:01:30	3.18 %M	4.254 g
Final mass :		4.090 g
Dry time:		0:01:45
Final result:		4.01 %M
Finish measurement		
Signature:.....		

Header

Measured value

Footers

8.2.5 P7 General functions

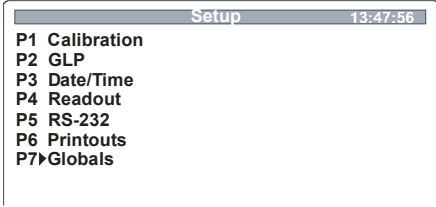
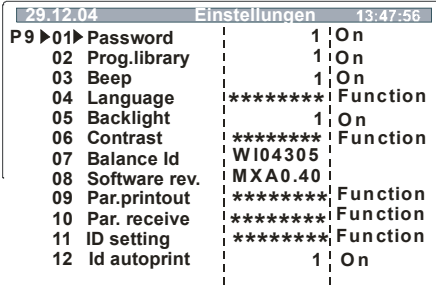
Operation	Display																								
<p>Call up menu item "P7 Others" (see chapt. 7.1)</p> <p>Press → button</p>	 <pre> Setup 13:47:56 P1 Calibration P2 GLP P3 Date/Time P4 Readout P5 RS-232 P6 Printouts P7▶Globals </pre>																								
01 – 12 Parameter selection																									
<p>Press the arrow keys (↓ ↑), to select your settings (01 – 12) .</p>	 <pre> 29.12.04 Einstellungen 13:47:56 P9 ▶01▶ Password 1 On 02 Prog.library 1 On 03 Beep 1 On 04 Language ***** Function 05 Backlight 1 On 06 Contrast ***** Function 07 Balance Id W104305 08 Software rev. MxA0.40 09 Par.printout ***** Function 10 Par.receive ***** Function 11 ID setting ***** Function 12 Id autoprint 1 On </pre>																								
<table border="0"> <tr> <td>01 Password</td> <td>Password protection</td> </tr> <tr> <td>02 Program library</td> <td>Program overview</td> </tr> <tr> <td>03 Signal</td> <td>Tone on/off</td> </tr> <tr> <td>04 Language</td> <td>User guidance selectable in German, English and Spanish</td> </tr> <tr> <td>05 Backlight</td> <td>Back lighting of the display on/off</td> </tr> <tr> <td>06 Contrast</td> <td>Contrast of the display</td> </tr> <tr> <td>07 Scales no.</td> <td>Balance identification no.</td> </tr> <tr> <td>08 Program no.</td> <td>Software issue</td> </tr> <tr> <td>09 Parameter printout</td> <td>Balance parameters are printed out</td> </tr> <tr> <td>10 Par.receive</td> <td>Not documented</td> </tr> <tr> <td>11 Set ID</td> <td>Entering a user code</td> </tr> <tr> <td>12 Auto ID printout</td> <td>User code can also be printed</td> </tr> </table> <p>Press the → -key; the current menu item blinks</p> <p>Use the arrow keys (see chapter 7.1) to save your settings</p> <p>Confirm settings by pressing the PRINT key</p> <p>Return to weighing mode: Press the ESC-key repeatedly until the query "SAVE?" appears. Confirm query by pressing the PRINT-key or reject it by pressing the ESC-key.</p>		01 Password	Password protection	02 Program library	Program overview	03 Signal	Tone on/off	04 Language	User guidance selectable in German, English and Spanish	05 Backlight	Back lighting of the display on/off	06 Contrast	Contrast of the display	07 Scales no.	Balance identification no.	08 Program no.	Software issue	09 Parameter printout	Balance parameters are printed out	10 Par.receive	Not documented	11 Set ID	Entering a user code	12 Auto ID printout	User code can also be printed
01 Password	Password protection																								
02 Program library	Program overview																								
03 Signal	Tone on/off																								
04 Language	User guidance selectable in German, English and Spanish																								
05 Backlight	Back lighting of the display on/off																								
06 Contrast	Contrast of the display																								
07 Scales no.	Balance identification no.																								
08 Program no.	Software issue																								
09 Parameter printout	Balance parameters are printed out																								
10 Par.receive	Not documented																								
11 Set ID	Entering a user code																								
12 Auto ID printout	User code can also be printed																								

9 Operator menu – moisture analysis

The device has space for up to 100 different, operator-defined drying processes. Simply invoke and start the finished processes (See chpt. 9.2). How to set drying parameters without using the program library is describes in the chapter below.

9.1 Moisture analysis without using the program library

9.1.1 Disabling the program library

To enter drying parameters at will disable the program library in the user menu as follows:

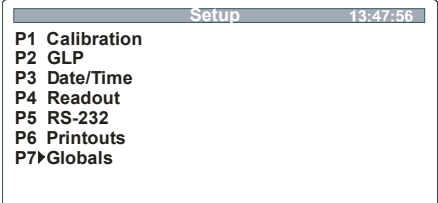
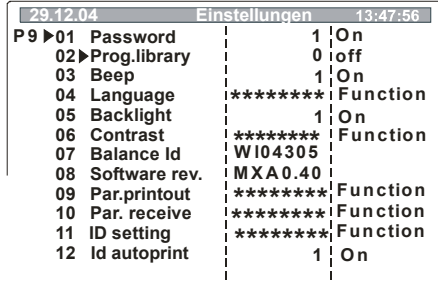
Operation	Display
<p>Press F key</p> <p>Press the arrow keys (↓ ↑), to invoke menu item “P7 Other“</p> <p>Press → button</p>	 <pre> Setup 13:47:56 P1 Calibration P2 GLP P3 Date/Time P4 Readout P5 RS-232 P6 Printouts P7>Globals </pre>
<p>Press the arrow keys (↓ ↑), to select „02–Program Library“</p> <p>Press the → button and the current setting will flash</p> <p>Press the arrow keys (↓ ↑), to disable the program library (0 = no)</p> <p>Confirm by pressing the PRINT key</p>	 <pre> 29.12.04 Einstellungen 13:47:56 P9 ▶01 Password 1 On 02▶Prog.library 0 off 03 Beep 1 On 04 Language ***** Function 05 Backlight 1 On 06 Contrast ***** Function 07 Balance Id WI04305 08 Software rev. MXA0.40 09 Par.printout ***** Function 10 Par. receive ***** Function 11 ID setting ***** Function 12 Id autoprnt 1 On </pre>
<p>Press the ESC-key repeatedly until the query ”SAVE?“ appears. Confirm query by pressing the PRINT-key</p>	

9.1.2 Setting drying parameters

You can enter parameters for each drying process in the menu, as follows:

- Heating profile (temperature, time)
- Shutoff criterion
- Unit of measured result
- Output interval

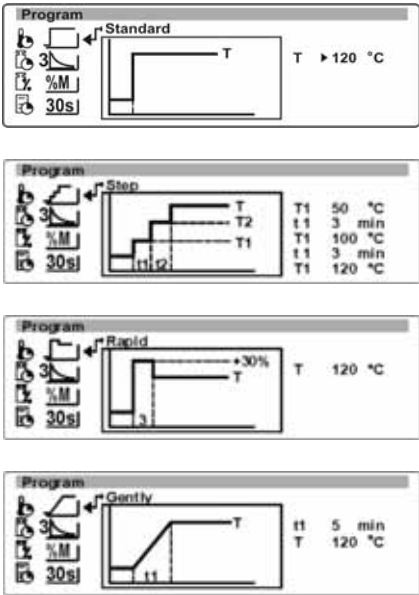
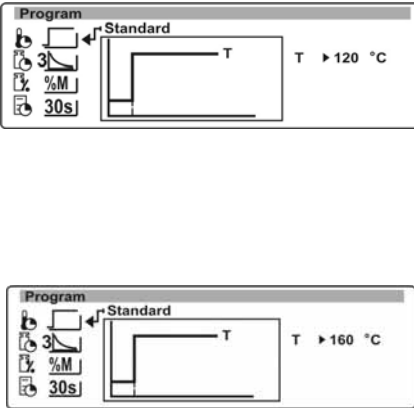
Operation	Display
<p>To enable the operator menu, press the Menu-key. The first menu item "Profiles" appears.</p>	
<p>1. Heating profiles This is used to select suitable heating programs as well as to enter drying temperature and drying time.</p>	
<p>→ Press button</p> <p>Press the arrow keys (↓ ↑), to select among the heating programs below (see also chpt. 11.8)</p> <ul style="list-style-type: none"> • Standard • Step-by-step • Soft • Fast 	
<p>First select a heating profile, then enter the desired parameters (temperature/drying time).</p> <p>Press the →-button; the cursor (▶) marks the adjustable parameter</p> <p>Press the →-button anew and the current setting will flash</p> <p>Press the arrow keys (↓ ↑), to carry out the desired setting</p> <p>Confirm by pressing the PRINT key</p> <p>For further parameter settings proceed as above</p>	

To return to menu, press the **PRINT**-key. This is where you can store further drying parameters.

or

Return to weighing mode:

Press the **ESC**-key repeatedly until the query "SAVE?" appears. Confirm query by pressing the **PRINT**-key or reject it by pressing the **ESC**-key.

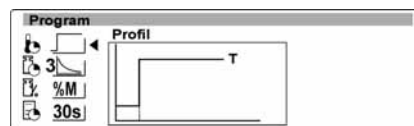

2. Shutoff criterion

This is used to select the criteria used for finishing the drying process.

Press the ↓ button; the menu item "Finish" appears.

Press → -button

Press the arrow keys (↓ ↑), to select among the finishing criteria:

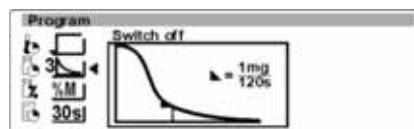
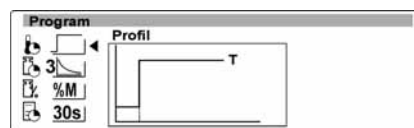

⇒ **Shutoff criterion mg per time**

Drying is shut off when the weight loss for the set time is smaller than the number of set digits (1 digit = 1mg)

How to select the desired setting:

Press → -button

Press the arrow keys (↓ ↑), to carry out the desired setting.

Automatic 1: Shutoff for change of weighing value ≤ 1mg within 20s.



Automatic 2: shutoff during change of weighing value < 1mg within 50s

Automatic 3: Shutoff for change of weighing value ≤ 1mg within 120s.

Automatic 4: shutoff during change of weighing value < 1mg within 180s

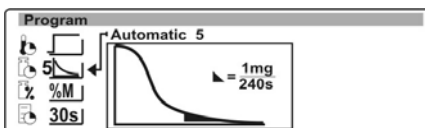
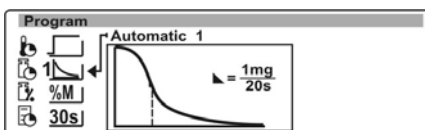
Automatic 5: shutoff during change of weighing value < 1mg within 240s

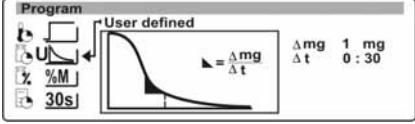
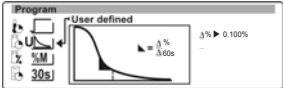
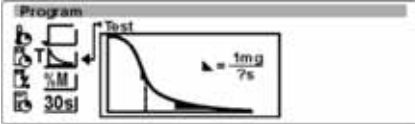

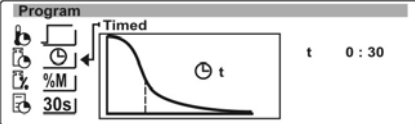
<p>⇒ Define Settings are available for selection from 0 to 10 mg in 0.1 mg steps and from 5 seconds to 175 in 5 second steps.</p> <p>Press → key; the cursor (▶) marks the adjustable parameter Press the →- button anew and the current setting will flash Press the arrow keys (↓ ↑), to carry out the desired setting Confirm by pressing the PRINT key</p>	
<p>⇒ Define 2 Drying is shut off as soon as the weight loss within 60 s is smaller than the set percentage value (adjustable from 0.001% to 9.999%).</p> <p>Press → key; the cursor (▶) marks the adjustable parameter Press the →- button anew and the current setting will flash Press the arrow keys (↓ ↑), to carry out the desired setting Confirm by pressing the PRINT key</p>	
<p>⇒ Test Shut off for change of weighing value ≤ 1mg in freely defined time interval</p>	
<p>⇒ Manual Shutoff drying process manual</p>	
<p>⇒ Temporal Drying is shut off when set time has passed, adjustable from 1min – 9h 59 min</p> <p>Press → -key; the cursor (▶) marks the adjustable parameter Press the →- button anew and the current setting will flash Press the arrow keys (↓ ↑), to carry out the desired setting Confirm by pressing the PRINT key</p>	

To return to menu, press the **PRINT**-key. This is where you can store further drying parameters.

or

Return to weighing mode:

Press the **ESC**-key repeatedly until the query "SAVE?" appears. Confirm query by pressing the **PRINT**-key or reject it by pressing the **ESC**-key.

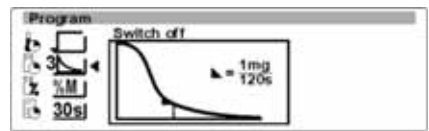

3. Unit of measured result

This is used to define the unit of the measured result.

Press the **↓** key; the menu item "Result" appears

Press **→** button

Press the arrow keys (**↓** **↑**), to select among **Types of Output:**

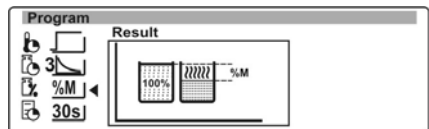
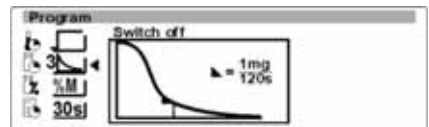

⇒ Calculation according to proportion of moisture

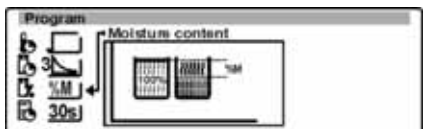

⇒ Calculation according to ATRO

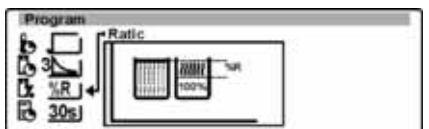

⇒ Calculation according to "g " moisture lost

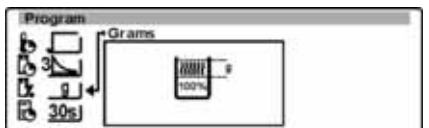

⇒ Calculation according to proportion of dryness

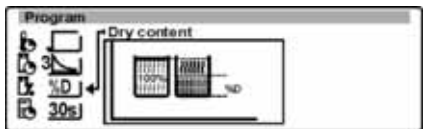

⇒ Calculation according to proportion of moisture, illustration in diagram

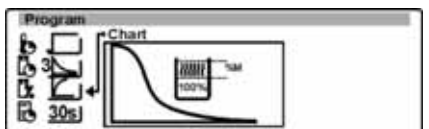

To return to menu, press the **PRINT**-key. This is where you can store further drying parameters.

4. Output interval

This is used to set at which interval interim results are to be printed.

Press the \downarrow -key; the menu item "Printout Interval" appears

Press \rightarrow button

Press the arrow keys (\downarrow \uparrow), to adjust the printer interval from 1 second to 5 minutes or to determine that no printout is required.

Confirm by pressing the **PRINT**-key.

Press the **PRINT**-key once more; the device returns to weighing mode.

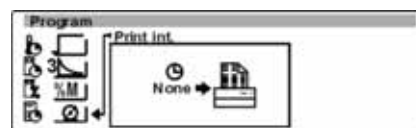
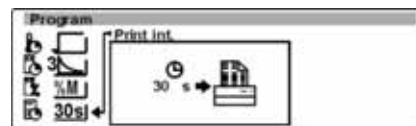
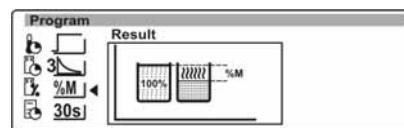

9.1.3 How to implement drying

After setting the desired drying parameter for the sample to be tested, you can now start the drying process.

You may of course also carry out drying with the help of the factory set drying parameters.

Display overview during drying:

The display during drying contains all the important information:

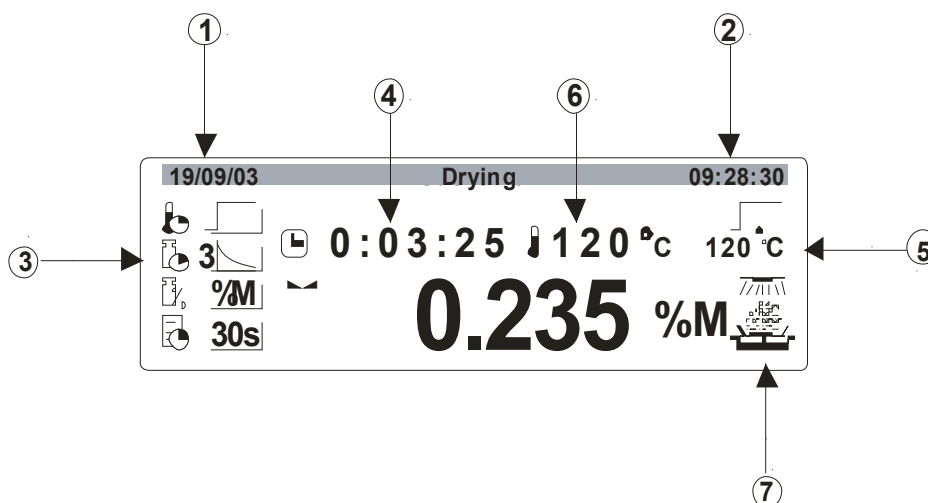

1. Date
2. Time
3. drying parameters: Heating profile / shutoff criteria / unit of measured result / output interval
4. Processing time
5. Target temperature
6. Processing temperature
7. Graphics showing current status

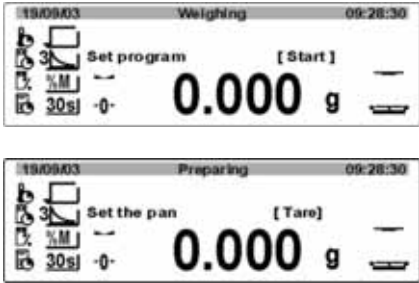
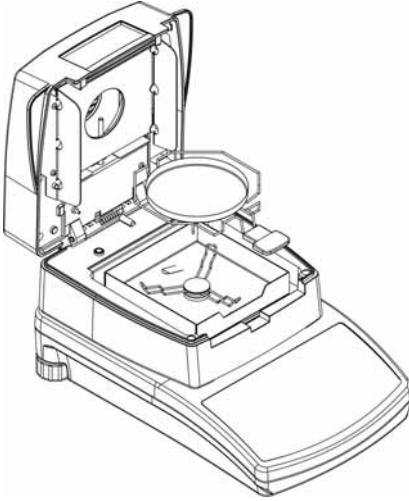
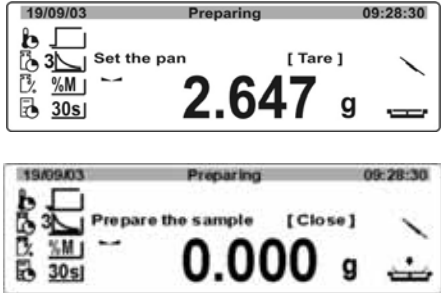
Operation	Display
<p>Actuate START/STOP-key</p>	
<p>Place removal aid with empty sample dish on the sample dish retainer. Make sure that the sample dish is resting flat on the sample dish retainer. Use the sample retainer at all times as it allows safe working and prevents burns.</p>	
<p>To help with stabilisation, close lid.</p> <p>Press the TARE-key; the device is ready for weighing the initial sampling quantity</p>	

Place sample in sample dish

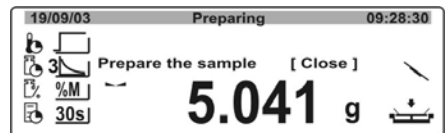
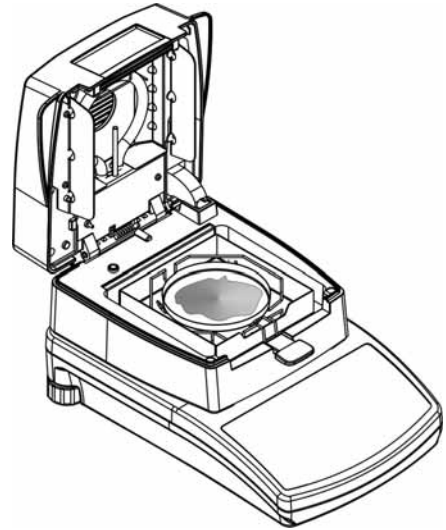

Close lid; the device is ready for measuring

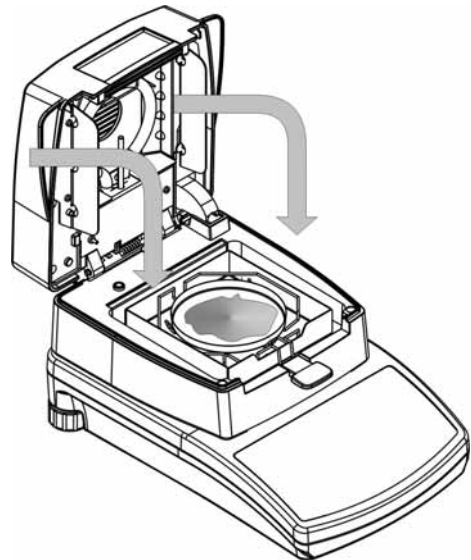

Drying will start automatically after scales have settled.

Drying parameters are shown on the display.

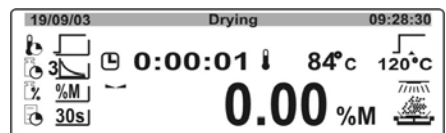

To switch the display to the various units of the measured result, press the **M**-key.

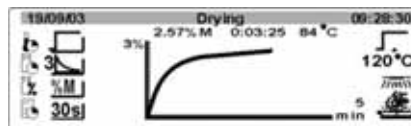

When drying is finished, you will hear an acoustic signal and the heating will be shut off.

The display shows the measured result in the set unit.

Open lid and remove the sample with the help of the removal aid.

Caution: Caution! Sample dish and all parts of the sample chamber are hot!

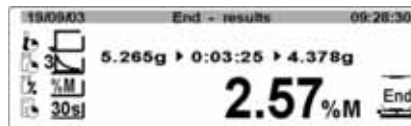

Data output via RS 232 interface is achieved by pressing the **PRINT**-key:

```

----- Start drying-----
Program no. : 1
Name       : Floar 100
Profile    : Standard
Dry temp.  : 120 °C
Switch off : Automatical 3
Result     : Moisture contents -
           : %M
Printout int : 30 s
Target     : None
T. coeficjent : 0.00

Start weight :          9.993 g

0:00:30      0.01 %M
0:01:00      0.02 %M
0:01:30      0.03 %M

Final mass :          9.990 g
Dry time   :          0:01:45
Final result :          0.03 %M

-----End of drying procedure-----
    
```

9.2 Moisture analysis using the program library

The device has a memory for drying processes! 99 drying processes can be allocated to this memory (library). Simply invoke and start the finished processes from the library.

9.2.1 Enabling of program library

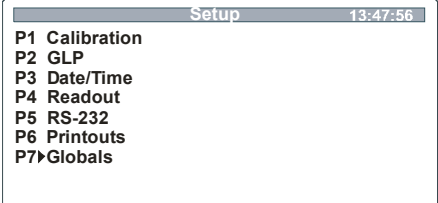
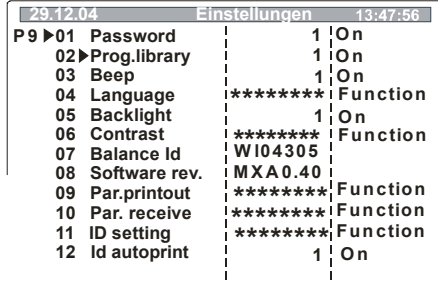
Operation	Display
Press F key Call up menu item " P7 Others " (see chapt. 7.1) Press → button	 <pre> Setup 13:47:56 P1 Calibration P2 GLP P3 Date/Time P4 Readout P5 RS-232 P6 Printouts P7>Globals </pre>
Press the arrow keys (↓ ↑), to select „ 02-Program Library “ Press the → -key; the current menu item blinks Press the arrow keys (↓ ↑), to enable the program library (1 = yes) Confirm by pressing the PRINT key	 <pre> 29.12.04 Einstellungen 13:47:56 P9 ▶01 Password 1 On 02▶Prog.library 1 On 03 Beep 1 On 04 Language ***** Function 05 Backlight 1 On 06 Contrast ***** Function 07 Balance Id WI04305 08 Software rev. MxA0.40 09 Par.printout ***** Function 10 Par. receive ***** Function 11 ID setting ***** Function 12 Id autoprnt 1 On </pre>
Press the ESC -key repeatedly until the query " SAVE? " appears. Confirm query by pressing the PRINT -key or reject it by pressing the ESC -key.	

After enabling the “program library” you will first be taken to the “program library” when starting a new drying process.

The library is used to save the parameters below:

- Denomination, e.g. the name of the sample (e. g. powder)
- Heating profile (e. g. soft)
- Drying temperature
- Shutoff criteria
- Unit of measured result
- Output interval
- Size of sample (g)
- Correction factor

9.2.2 Setting drying parameters

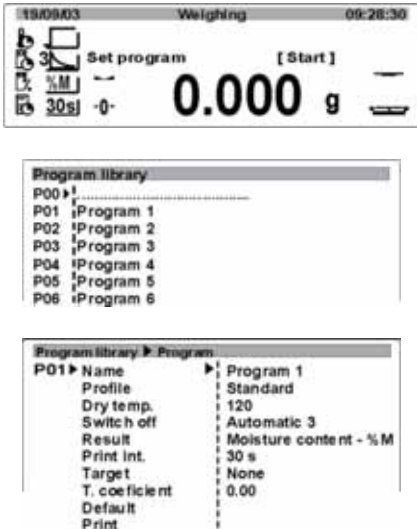
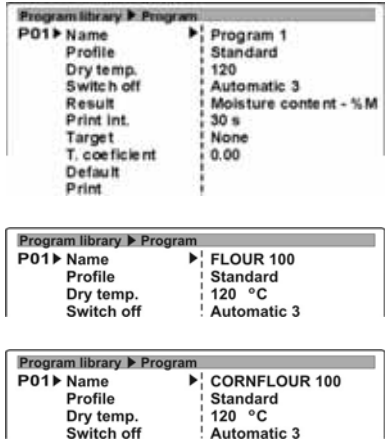
Operation	Display
<p>Press Menu-key; library opens</p> <p>Information: The most recent program used is shown in P00</p> <p>Press the arrow keys (↓ ↑), to select “Program No“</p> <p>Press → -key; parameter options of program appear. Parameter selection is achieved with the help of the arrow keys (↓ ↑)</p>	
<h3>1. Name</h3>	
<p>Press the →-key; the current menu item blinks</p> <p>How to enter the desired denomination:</p> <p>Press the ↓ ↑ keys, to select the characters</p> <p>Press the ← → keys, to select the digit on the left/right (relevant enabled digit flashes).</p> <p>Confirm entry by pressing the PRINT-key and enter additional parameters as follows.</p>	
<h3>2. Profile</h3> <p>This is used to select a suitable heating program as well as to enter drying chamber temperature and drying time.</p>	

Press the arrow keys (↓ ↑), to select “Profile“

Press → -button

Press the →-key anew; the current menu item blinks

Press the arrow keys (↓ ↑), to select among the heating programs below plus the related parameters

- **Standard**
- **Step-by-step**
It is possible to increase the temperature step-by-step. The number and size of steps can be selected at will, see chpt. 11.8.
- **Soft**
Temperature is slowly increased. It is possible to adjust the lengths of the ramp, see chpt. 11.8
- **Fast**
Temperature is increased very quickly and for a short while exceeds the set temperature value. Afterwards the temperature is lowered to processing temperature and kept there until the end of the process, see chpt. 11.8

Confirm by pressing the **PRINT** key

The heating program is selected first, followed by the related parameters. (temperature/drying time)

Press the → -button; the cursor (▶) marks the adjustable parameter

Press the →- button anew and the current setting will flash

Press the arrow keys (↓ ↑), to carry out the desired setting

Confirm entry by pressing the **PRINT**-key and enter additional parameters as follows.

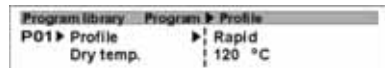
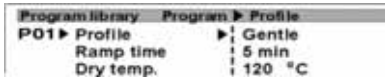
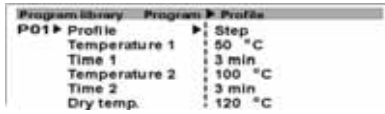
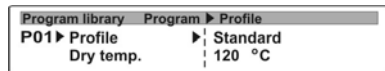
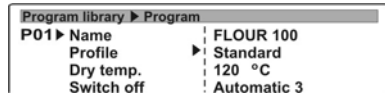

For the selection of "standard" or "fast" enter temperature afterwards

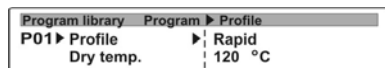
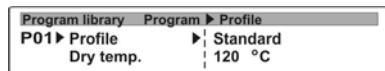

For the selection of “soft“ enter temperature and drying time afterwards

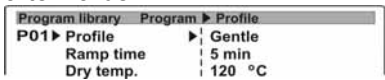

For the selection of “step-by-step“ enter temperature and drying time for step “1” and “2” afterwards

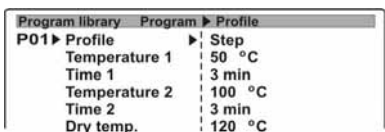

3. Drying temperature

This is used to enter the drying temperature a second time. This setting overwrites the drying time entered under the menu item **“Profile“**.

Press the arrow keys (↓ ↑), to select the **“Drying Temperature”**

Press the → -key; currently set temperature flashes

Press the arrow keys (↓ ↑), to enter the desired temperature.

Confirm entry by pressing the **PRINT**-key and enter additional parameters as follows.

```
Program library ▶ Program
P01▶ Name       FLOUR 100
   Profile      Standard
   Dry temp.    120 °C
   Switch off   ▶ Automatic 3
```

4. Finish/shutoff criterion

This is used to select the criteria determining how drying is to be finished.

Automatic 1	Shutoff for changes to weighing value \leq 1mg within 20s
Automatic 2	Shutoff for changes to weighing value \leq 1mg within 50s
Automatic 3	Shutoff for change of weighing value \leq 1mg within 120s.
Automatic 4	Shutoff for change of weighing value \leq 1mg within 180s.
Automatic 5	Shutoff for changes to weighing value \leq 1mg within 240s
Time defined	Adjustable from 1 min – 9h 59 min
Manual	after pressing key
Defined/ Defined 2	Shutoff for changes to weighing value in set time, (Δm 0.1-9.9mg / Δt max 2.55 min.)
Test	Shutoff for changes to weighing value \leq 1mg in freely defined time interval

Press the arrow keys (↓ ↑), to select “**Shutoff**”

Press the → -key for the current setting to appear

Press the →-key; the current menu item blinks

Press the arrow keys (↓ ↑), to select desired shutoff criterion. For further details, see chpt. 9.1.2 “Shutoff Criterion”.

Confirm entry by pressing the **PRINT**-key and enter additional parameters as follows.

```

Program library ▶ Program
P01 ▶ Name      FLOUR 100
      Profile    Standard
      Dry temp.  120 °C
      Switch off ▶ Automatic 3
  
```

5. Unit of measured result in display or printout (can be switched between %M, %D, %R, g)

Press the arrow keys (↓ ↑), to select “**Result**”

Press the → -button and the current setting will flash

Press the arrow keys (↓ ↑), to select desired setting. For further details see chpt. 9.1.2 “Unit of Measured Result”.

Confirm entry by pressing the **PRINT**-key and enter additional parameters as follows.

```

Program library ▶ Program
P01 ▶ Name      FLOUR 100
      Profile    Standard
      Dry temp.  120 °C
      Switch off  Automatic 3
      Result     ▶ Moisture content - %M
      Print int. 30 s
      Target     None
  
```

6. Output interval

This is used to set at which interval interim results are to be printed.

Press the arrow keys (↓ ↑), to select “**Printout Time**”

Press the → -button and the current setting will flash

Press the arrow keys (↓ ↑), to select desired setting. For further details see chpt. 9.1.2 “Output Interval”.

Confirm entry by pressing the **PRINT**-key and enter additional parameters as follows.

```

Program library ▶ Program
P01 ▶ Name      FLOUR 100
      Profile    Standard
      Dry temp.  120 °C
      Switch off  Automatic 3
      Result     ▶ Moisture content - %M
      Print int. 30 s
      Target     None
  
```

7. How to enter a target weight for a sample

The user can enter a target weight stating a tolerance range for the sample. This entry facilitates the application of identical sample sizes for each drying process.

Press the arrow keys (↓ ↑), to select “**Sample**”

Press the → -key for the current setting to appear

Press the →-key; the current menu item blinks

Press the arrow keys (↓ ↑), to select among the settings below

- **None**
Function disabled
- **Optional**
A message appears giving information whether the sample weight is within the entered tolerance limits. The drying process will be started even if the sample weight is beyond the defined tolerance limits.
- **Obligatory**
A message appears giving information whether the sample weight is within the entered tolerance limits. The drying process will only be started if the sample weight does not exceed the defined tolerance limits.

Confirm settings by pressing the **PRINT** key.

After selecting **optional** or **obligatory** enter the target weight and tolerance limits.

Press the arrow keys (↓ ↑), to select the parameters

Press the → -button and the current setting will flash

Press the arrow keys (↓ ↑), to carry out the desired setting

Confirm entry by pressing the **PRINT**-key and enter additional parameters as follows.

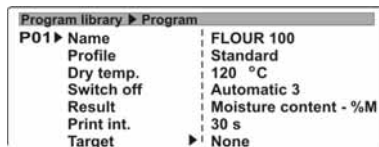

```
Program library > Program
P01 ▶ Name      FLOUR 100
    Profile     Standard
    Dry temp.   120 °C
    Switch off   Automatic 3
    Result      Moisture content - %M
    Print int.  30 s
    Target      ▶ None
```

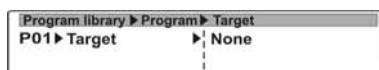

```
Program library > Program > Target
P01 ▶ Target    ▶ None
```

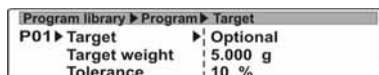

```
Program library > Program > Target
P01 ▶ Target    ▶ Optional
    Target weight 5.000 g
    Tolerance     10 %
```

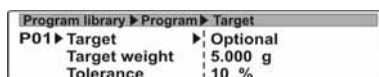

```
Program library > Program > Target
P01 ▶ Target    ▶ Optional
    Target weight 5.000 g
    Tolerance     10 %
```

8. Determine and enter **corrective factor**

Certain materials emit more heat than is introduced from the outside. Dark substances for instance absorb heat and falsify measured results.

In order to achieve an accurate measured result it is necessary to make a correction. Setting a corrective factor allows the user to correct differences between the set temperature of the moisture meter and the actually measured temperature on the specimen with the help of a temperature calibration set.

Determination of corrective factor:

- Carry out drying on sample
- Record measured result
- Carry out drying on second sample. For this purpose choose a sample amount that is large enough to dip the measuring probe of the temperature calibration set into the sample.
- Record measured result of moisture meter und temperature calibration set.
- Determination of corrective factor according to the formula below:

$$\text{Correction} = \frac{T (\text{measured}) - T (\text{set})}{T (\text{set})}$$

Example: The measured temperature is 121°C, the set temperature is 110°C; from this follows a correction of 0.11.

Typical materials with high temperature emission:

Material	Set temperature	Measured temperature	Correction factor
Flour	100°C	103.7°C	0.04
Coal dust	100°C	122°C	0.22
Damp tea leaves	100°C	120.5°C	0.20
Dry tea leaves	100°C	108.5°C	0.08
Cement	100°C	121°C	0.21

How to enter the determined corrective factor:

Press the arrow keys (↓ ↑), to select “**Corrective Factor**”

Press the → -button and the current setting will flash

Press the arrow keys, to enter the determined corrective factor

Use the ↓ ↑, to select the digit

Press the ← → keys, to select the digit on the left/right (relevant enabled digit flashes).

Confirm setting by pressing the **PRINT**-key and enter additional parameters as follows.

Program library ▶ Program	
P01▶ Name	Program 1
Profile	Standard
Dry temp.	120 °C
Switch off	Automatic 3
Result	Moisture content - %M
Print int.	30 s
Target	None
T. coefficient	▶ 0.00
Default	
Print	

9. Standard setting

This setting is used to set all drying parameters to factory settings.

Press the arrow keys (↓ ↑), to select “**Standard**”

Press the → -key; Query “Standard?” appears

Confirm by pressing the **PRINT**-key; drying parameters are reset to factory settings.

The device returns to the menu.

If the drying parameters are not reset to factory settings, press the **ESC**-key.

Program library ▶ Program	
P01▶ Name	Program 1
Profile	Standard
Dry temp.	120 °C
Switch off	Automatic 3
Result	Moisture content - %M
Print int.	30 s
Target	None
T. coefficient	0.00
Default	▶
Print	

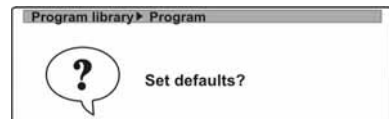

Program library ▶ Program	
P01▶ Name	Program 1
Profile	Standard
Dry temp.	120 °C
Switch off	Automatic 3
Result	Moisture content - %M
Print int.	30 s
Target	None
T. coefficient	0.00
Default	▶
Print	

10. Printing drying parameters

If the device is connected to an optional printer the drying parameters settings can be printed out

Press the arrow keys (↓ ↑), to select “Print”

Press → -key; query “Print Program?” appears

Confirm by pressing the **PRINT**-key, drying parameters are printed.

Example:

```
----- Program parameters -----  
  
Program no.      : 1  
Name             : FLOUR 100  
Profile          : Standard  
Dry temp.       : 120 °C  
Switch off      : Automatic 3  
Result          : Moisture content %M  
Print int.      : 30 s  
Target          : None  
T. coefficient   : 0.00  
  
-----
```

The device returns to the menu.

If the drying parameters are not printed press the **ESC**-key.

```
Program library ▶ Program  
P01 ▶ Name      Program 1  
Profile        Standard  
Dry temp.      120 °C  
Switch off     Automatic 3  
Result         Moisture content - %M  
Print int.     30 s  
Target         None  
T. coefficient  0.00  
Default  
Print         ▶
```

```
Program library ▶ Program  
  
? Print program?
```

```
Program library ▶ Program  
P01 ▶ Name      FOLUR 100  
Profile        Standard  
Dry temp.      120 °C  
Switch off     Automatic 3  
Result         Moisture content - %M  
Print int.     30 s  
Target         None  
T. coefficient  0.00  
Default  
Print         ▶
```

9.2.3 How to save drying parameters

After all drying parameters have been set, press the **ESC**-key

The query “Save Program?” appears

Confirm by pressing the **PRINT**-key; the drying parameters of the program are saved.

The device returns to the program library.

If the drying parameters are not saved, press the **ESC**-key.

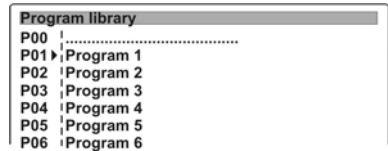
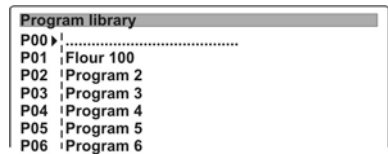
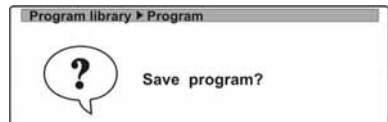
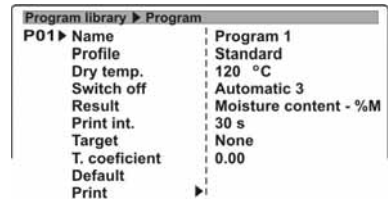

9.2.4 How to invoke drying parameters / drying

When the program library (see chpt. 9.2.1) is enabled, invoke the desired drying program as follows.

Operation	Display
<p>Press Menu-key; program library appears</p>	
<p>Press the arrow keys (↓ ↑), to select the desired drying program</p> <p>Confirm by pressing the PRINT key.</p> <p>The device is ready to carry out drying according to the invoked drying parameters</p>	

Press **START/STOP**-key

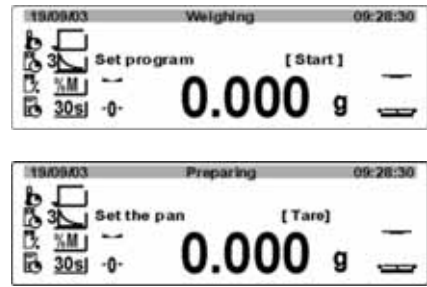

Place removal aid with empty sample dish on the sample dish retainer. Make sure that the sample dish is resting flat on the sample dish retainer. Use the sample retainer at all times as it allows safe working and prevents burns.

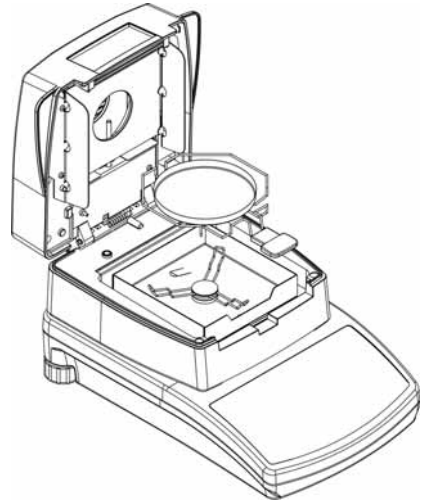

To help with stabilisation, close lid.

Press the **TARE**-key; the device is ready for weighing the initial sampling quantity

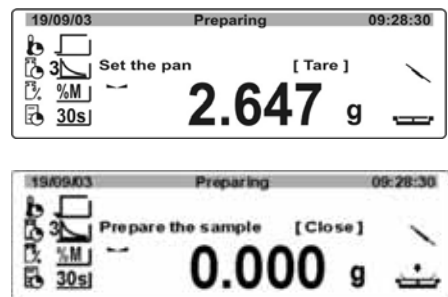

Place sample in sample dish

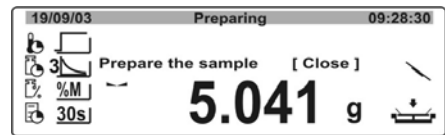
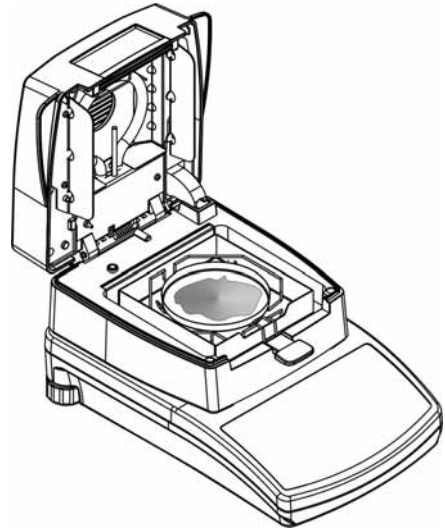

Close lid; the device is ready for measuring

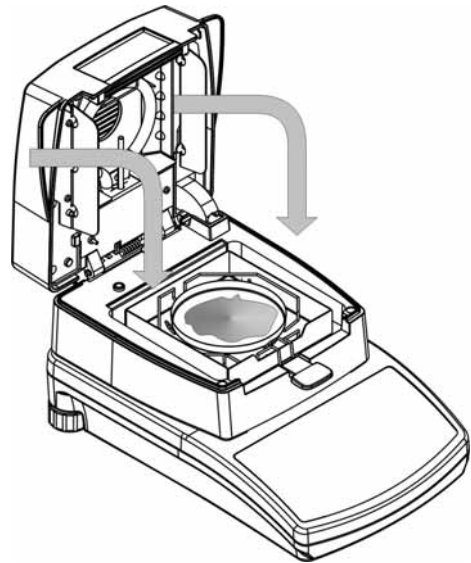

Drying will start automatically after scales have settled.

You can read the processing parameters (target temperature, processing temperature, type of calculation etc.) on the display.

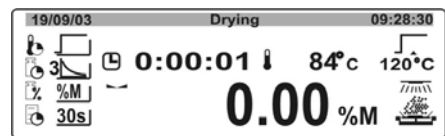

To switch the display to the various units of the measured result, press the **M**-key.

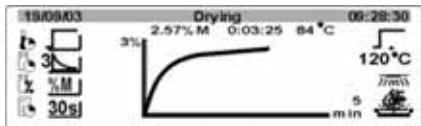

When drying is finished, you will hear an acoustic signal and the heating will be shut off.

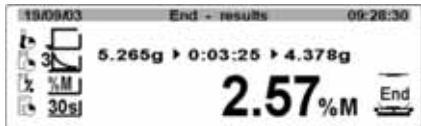

The display shows the measured result in the set unit.

Open lid and remove the sample with the help of the removal aid.

Caution: Sample dish and all parts of the sample chamber are hot!

Data output via RS 232 interface is achieved by pressing the **PRINT**-key:

```

----- Start drying-----
Program no. : 1
Name       : Floar 100
Profile    : Standard
Dry temp.  : 120 °C
Switch off : Automatical 3
Result     : Moisture contents -
           : %M
Printout int : 30 s
Target     : None
T. coeficjent : 0.00

Start weight :          9.993 g
0:00:30      :          0.01 %M
0:01:00      :          0.02 %M
0:01:30      :          0.03 %M

Final mass :          9.990 g
Dry time   :          0:01:45
Final result :          0.03 %M

-----End of drying procedure-----
    
```

10 Storing measured results

The device is able to store the most recently carried out measurements (max. 100 measurements). In addition to the measured result, all drying parameters are also stored.

When 100 measurements have been allocated to the memory the next measurement (101) will be saved under position 99. For this purpose the entire memory list is shifted up by one space.

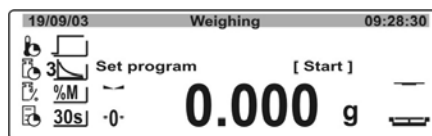

In weighing mode press the **M**-key and the memory list will open

Results		
00	28/06/05	10:19:26
01	28/06/05	11:15:30
02	29/06/05	09:45:30 Tea
03	29/06/05	09:56:45 Tea

Press the arrow keys (↓ ↑), to select the desired measurement

Results		
00	28/06/05	10:19:26
01	28/06/05	11:15:30
02	29/06/05	09:45:30 Tea
03	29/06/05	09:56:45 Tea

Press the → -key; all parameters relevant for this measurement are displayed

Results		29/06/05	09:45:30
02	Name		Tea
	Profile		Standard
	Dry temp.		160°C
	Total time		0:43:20
	Start weight		5.6783 g
	Final weight		5.3218 g
	Final result		5.26%M

To print out this data, press the **PRINT**-key.

11 General information concerning moisture analysis

11.1 Application

In all cases where moisture is added to or removed from products, a fast determination of the moisture content is of enormous importance. For countless products the moisture content is not only a quality feature but also an important cost factor. Very often fixed limits for moisture content apply to the trade in industrial or agricultural goods as well as chemical or food products which are defined by terms of delivery and general standards.

11.2 Basics

Moisture does not only mean water but includes all substances that evaporate when heated up. In addition to water this includes,

- Fats
- Oils
- Alcohol
- Solvents
- etc...

There are various methods to analyse moisture in a product.

KERN MLS uses a method called thermogravimetrics. In accord with this method, the sample is weighed before and after heating, determining the material moisture by looking at the difference.

The conventional drying chamber method follows the same principle, with the exception that this method requires a considerably longer measuring period. . In accord with the drying chamber method, the sample is heated from the outside to the inside by a hot air current, so as to remove the moisture. The radiation applied in the KERN MLS penetrates mainly the sample in order to be transformed inside it into heat energy that is, warming from the inside to the outside. A minor amount of radiation is reflected by the sample, a reflection that is less in dark samples than in light-coloured ones. The depth of penetration of the radiation depends on the permeability of the sample. In samples of low permeability the radiation only penetrates the outer layers of the sample, possibly resulting in imperfect drying, incrustation or burning. For that reason the preparation of a sample is of great importance.

11.3 Adjustment to existing measuring method

Quite frequently the KERN MLS replaces a different drying method (such as a drying chamber) as the KERN MLS achieves shorter measuring times during a simplified operation. For that reason the conventional measuring method must be matched to the KERN MLS in order to achieve comparable results.

- Carry out parallel measurement
Lower temperature setting for KERN MLS than drying chamber method
- Result of KERN MLS does not match reference
 - Repeat measurement with changed temperature setting
 - Vary shutoff criterion

11.4 Preparing a sample

Prepare one sample at a time for measuring. This prevents the sample from exchanging moisture with its surroundings. If several samples have to be taken at

the same time, they should be packed in airtight boxes so that they do not undergo changes during storage.

To receive reproducible results, spread the sample thinly and evenly on a sample dish.

Patchy spreads will produce inhomogeneous heat distribution in the sample to be dried resulting in incomplete drying and increased measuring time. Sample clusters generate increased heating of the upper layers resulting in combustion or incrustation. The high layer thickness or possibly arising incrustation makes it impossible for the moisture to escape from the sample. Due to this residual moisture, measured results calculated in this way will not be comprehensible or reproducible.

Preparing a sample from bulk material:

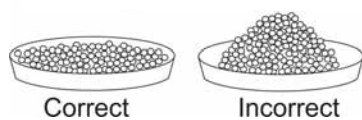

No special sample preparations are necessary for bulk materials.

Spread powdery or grainy samples evenly on the sample dish.

Coarse sample may need crushing (grind, crush using a mortar).

Preparing a sample from liquids:

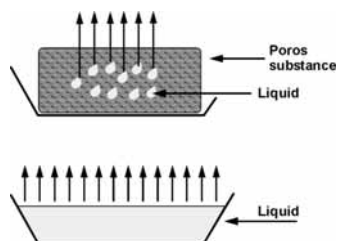

This, too, does not require any special sample preparation.

Spread glutinous or sticky samples thinly. It is advisable to use glass fibre filters.

Weight loss caused by splashes can be prevented by covering the sample with a glass fibre filter. If using glass fibre filters, their weight has to be deducted from the gross weight.

Preparing a sample from solids:

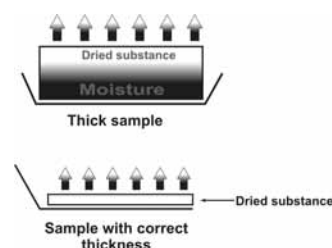

In this case special preparation of the sample is advisable, as drying, in particular the drying time, depends on the surface as well as the thickness of the sample.

11.5 Sample material

Easy to determine are usually samples with the following characteristics:

- Grainy to powdery, pourable solids
- Thermally stable materials, emitting the moisture to be determined easily without other substances evaporating at the same time
- Liquids that vaporize to leave a dry substance without developing a film

Difficult to determine may be samples that are:

- Glutinous or sticky
- Become incrustrated easily or tend to form a film
- Decompose easily under the influence of heat or emit various elements

11.6 Sample size / originally weighted in quantity

Drying times, as well as achievable accuracy, are significantly influenced by sample distribution. In the course of this arise two opposed requirements:

The lighter the originally weighted in quantity, the easier it is to achieve shorter drying times.

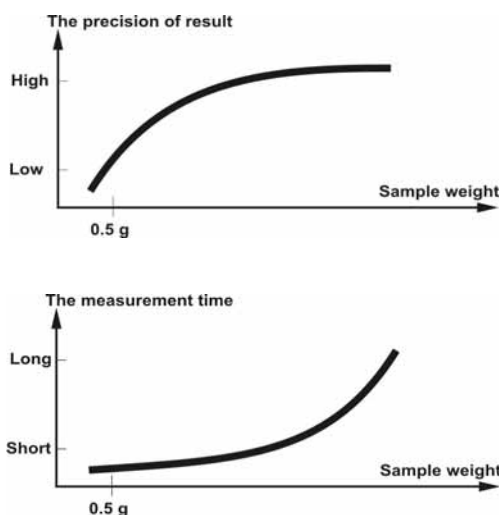

However, the heavier the originally weighted in quantity, the more accurate a result (example of a sample with ideal characteristics) will be achieved.

Poured quantity	Reproducibility
0.5g	±0.6%
1g	±0.3%
2g	±0.15%
5g	±0.06%
10g	±0.03%

11.7 Drying temperature

Bear in mind the following factors when setting the drying temperature:

Surface of the sample:

Compared with powdery or grainy samples, liquid and spreadable samples have a smaller surface for the transmission of heat energy.

The use of a glass fibre filter improves the heat application.

Colour of sample:

Light-coloured samples reflect more heat radiation than dark ones and therefore require a higher drying temperature.

Availability of volatile substances:

The better and faster the water or other volatile substances can be disposed, the lower a drying temperature is required. If water is difficult to get to (e. g. in synthetics), it has to be calcined at high temperatures (the higher the temperature, the higher the water vapour pressure).

Results equivalent to other moisture analysing methods (e. g. drying chamber) can be achieved by experimentally optimising the setting parameters such as temperature, heating level and shutoff criteria.

11.7.1 Drying temperatures above 160 °C (MLS 50-3HA250N only)

For measurements within a temperature range from 161°C – 250°C, the heating period is limited to 1 hour for up to 161°C and 20 minutes at 250°C.

The maximum temperature of 250°C is kept for 20 minutes and afterwards lowered automatically within 20 minutes to 160°C (drying process is not interrupted).

11.8 Description of heating profiles

4 heating profiles are available, as follows:

- Standard
- Fast
- Soft
- Step-by-step drying

Standard drying

Standard drying is the most frequently used drying process. This type of heating method is suitable for the majority of substances.

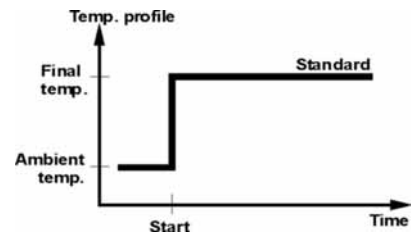

Soft drying

The soft heating method is suitable for substances that are unable to tolerate a sudden rise in temperature applied by radiators. There are also those substances that form a film when warmed up quickly. This film will afterwards affect the evaporation of the enclosed moisture. For such substances, the soft mode of warming is equally suitable.

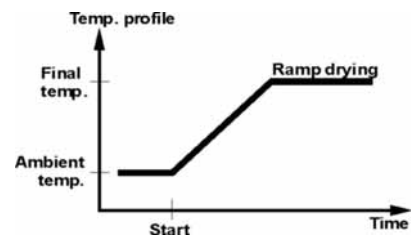

Fast drying

The fast heating profile is suitable for samples with a moisture content of 5% to 15%. The temperature is increased very quickly and, for a short while, will exceed the set drying temperature. After that the temperature will be adjusted down to the set value. The sample must contain enough moisture.

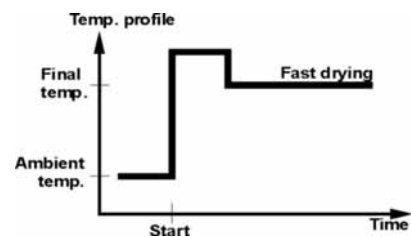

Step-by-step drying

Step-by-step drying is suitable for substances that display special behaviour during warming. The individual steps are freely selectable regards duration and temperature rising step. Samples should have a moisture content of at least 15%.

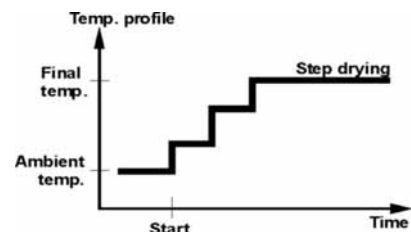

11.9 Recommendations / Guidelines

Prepare standard sample:

- Crush sample, as required, and spread it evenly in the aluminium dish.

Prepare special samples:

- For sensitive or hard to spread test materials (e. g. mercury) a glass fibre filter is available for use.
- Spread sample evenly on glass fibre filter and cover is with a second glass fibre filter.
- The glass fibre filter is also useful as a protection when splashing materials are dealt with (each splash falsifies the final result).

MATERIAL	Specimen weight (g)	Drying temperature (° C)	Data query interval (s)	% moisture % solid	Drying time (min)
Dried piece of apple	5-8	100	10	76.5	10-15
Moist apple	5-8	100	10	7.5	5-10
Butter	2-5	138	15	16.3	4.5
Mustard	2-3	130	20	76.4	10
Ground coffee	2-3	106	5	2.8	4
Cornflakes	2-4	120	15	9.7	5-7
Yoghurt	2-3	110	15	86.5	4.5-6.5
Cocoa powder	2-3	106	20	0.1	2
Margarine	3-4	138	20	16	10
Milk powder	2-4	90	15	5	6
Red wine	3-5	100	15	97.4	15-20
Sunflower oil	10-14	138	20	0.1	2
Sugar	4-5	138	15	11.9	10
Milk	2-3	120	15	88	6-8
Flour	8-10	130	10	12.5	4-5
Cement	8-12	138	15	0.8	4-5
Paper	2-4	106	20	6.4	10

12 Data output

Pin allocation of the balance output plug (front view):

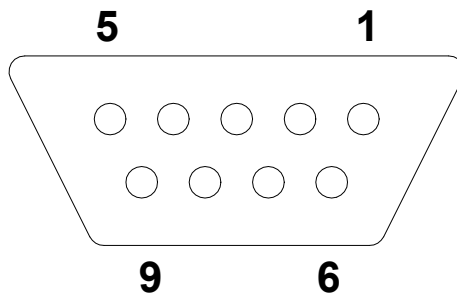

Pin 2: Receive data
 Pin 3: Transmit data
 Pin 5: Signal ground

Interface cable:

⇒ Balance - printer

3 (TxD)	1 (RxD)
5 (GND)	3 (GND)
7 - 8 clench	

⇒ Balance – PC 9-pole

2 (RxD)	3 (TxD)
3 (TxD)	2 (RxD)
5 (GND)	5 (GND)
4 - 6 clench	4 - 6 clench
7 - 8 clench	7 - 8 clench

⇒ Balance – PC 25-pole

2 (RxD)	3 (TxD)
3 (TxD)	7 (GND)
5 (GND)	4 - 5 clench
7 - 8 clench	6 - 20 clench
2 (RxD)	

12.1 Remote control instructions

Commands	Function
R CR LF	Reset to manufacturer setting - reset
PC CR LF	Command to call up the values of the balance
S CR LF	Transfer of stable weighing values in standard weighing unit
SI CR LF	Transfer of instable weighing values in standard weighing unit
SU CR LF	Last stable measuring value
SU CR LF	Current measuring value
Z CR LF	Zeroing stable value
ZI CR LF	Zeroing instable value
T CR LF	Taring stable value
TI CR LF	Taring instable value
C0 CR LF	Cancel continuous data output
C1 CR LF	Start continuous data output
NB CR LF	Serial no. of balance
FS CR LF	Weighing range max.
RV CR LF	Software issue
PD CR LF	Date display
PD CR LF	Time display
PMCR LF	Operating mode
PS CR LF	Balance parameters are printed out
B CR LF	Tone
ER CR LF	Call up error message
DH CR LF	Display check status bar
CH CR LF	Display check status bar delete
DF CR LF	Display check capacity display
CF CR LF	Display check capacity display
CL CR LF	Start internal adjustment from outside
KL CR LF	Lock keyboard
KU CR LF	Unlock keyboard
E0 CR LF	Key-tone off
E1 CR LF	Key-tone on
O0 CR LF	Balance off
O1 CR LF	Balance on
A0 CR LF	Auto zero off
A1 CR LF	Auto zero on
PP n CR LF	No. of user-defined data output

13 Service, maintenance, disposal

13.1 CLEANING

Before cleaning, please disconnect the appliance from the operating voltage.

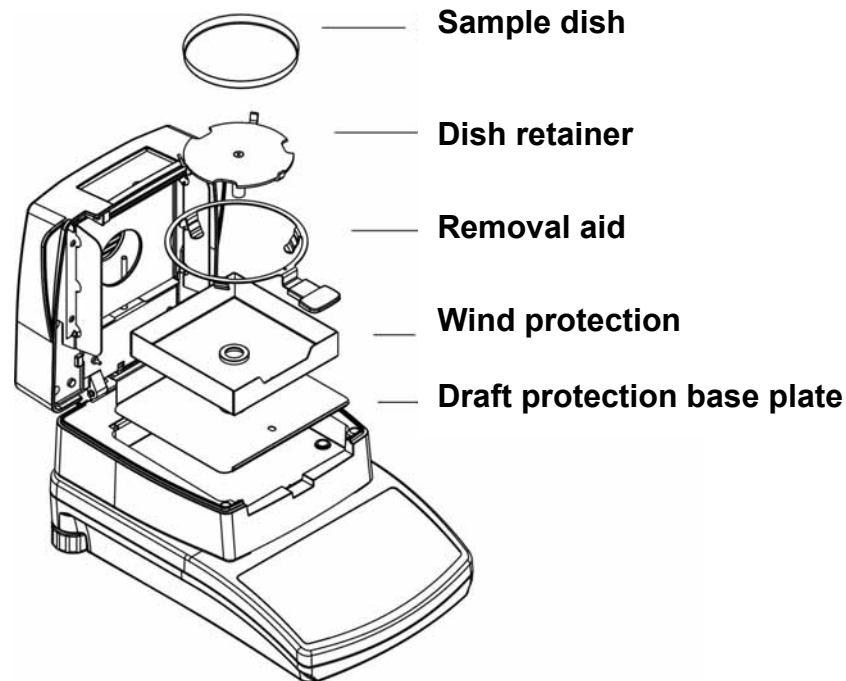

For cleaning purposes remove the accessory parts one after the other (see illustration).

Please do not use aggressive cleaning agents (solvents or similar agents), but a cloth dampened with mild soap suds. Ensure that no liquid penetrates into the device and wipe with a dry soft cloth.

Loose residue sample/powder can be removed carefully with a brush or manual vacuum cleaner.

Spilled weighing goods must be removed immediately.

Cleaning the temperature sensor:

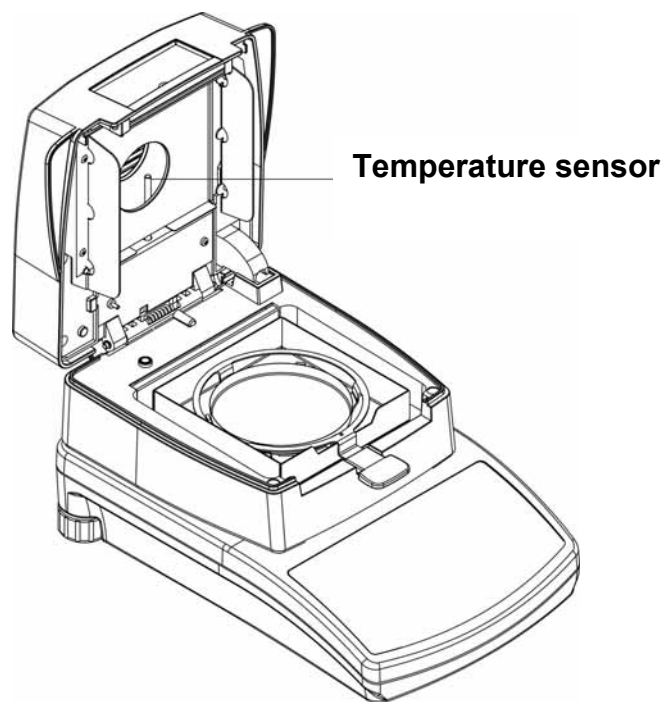

Clean the same way, as described above. Take care that the radiator is not touched, or worse, damaged.

13.2 Service, maintenance

The appliance may only be opened by trained service technicians who are authorized by KERN. Before opening, disconnect from power supply.

13.3 Disposal

Disposal of packaging and appliance must be carried out by operator according to valid national or regional law of the location where the appliance is used.

14 Instant help

In case of an error in the program process, briefly turn off the balance and disconnect from power supply. The weighing process must then be restarted from the beginning.

Help:

Fault

Possible cause

The displayed weight does not glow.

- The balance is not switched on.
- The mains supply connection has been interrupted (mains cable not plugged in/faulty).
- Power supply interrupted.

Measurement is taking too long

- Incorrect setting shutoff criterion

Measurement is not reproducible

- Sample is not homogenous
- Drying time is too short
- Drying temperature too high (e.g. oxidation sample material, boiling point of sample exceeded)
- Temperature sensor soiled or defective

The displayed weight is permanently changing

- Draught/air movement
- Table/floor vibrations
- Weighing plate has contact with other objects.
- Electromagnetic fields / static charging (choose different location/switch off interfering device if possible)

Weighing result obviously wrong or not reproducible

- The display of the balance is not at zero
- Adjustment is no longer correct.
- Great fluctuations in temperature.
- Electromagnetic fields / static charging (choose different location/switch off interfering device if possible)

Error messages	No.	Description
Error of control sum	1.1	Error data transmission
Error A/D	1.2	Error A/D converter
Exceed range	2.1	Out of weighing range
A/D Null	2.3	Error A/D converter
A/D Full	2.4	Error A/D converter
Tara/Zero outside the range	2.5	Out of weighing range
Tara outside the range	2.6	Out of taring range
Result > 10% Max	2.7	Result > 10%
Result > 4% Max	2.8	Load on weighing tray too heavy
The difference > 1% Max	2.9	Difference between cal. weight and stored/current cal. weight > 1%
The sample mass < 1g	2.10	Sample < 1g
The sample mass outside the range	2.11	Sample out of set range
Outside range	3.1	Value of parameter outside
Faulty value	3.2	Value of parameter outside
Incorrect password	3.4	Wrong password
Record error	4.1	Error data transmission
Parity error	4.2	
Table error	4.3	
Suspended transmission CTS	4.4	
Suspended transmissionXOFF	4.5	
Incorrect date	5.1	Wrong date
Overcrossed time	6.1	Time exceeded

Should other error messages occur, switch balance off and then on again. If the error message remains inform manufacturer.